

工作·养生 | Healthy Working

本书中的尺寸及颜色样板仅供参考，请以实物为准。
敬请留意，由于印刷技术所限制，故此图片表示之纹理、物料及颜色与真实产品可能稍有偏差。
Please be advised that due to printing limitations and product variation resulting from different textures and materials, colors shown are approximations.



COLLECTIONS

Welcome to EagleSeating
欢迎来到易高斯登来

佛山市易高斯登家具有限公司
EAGLESEATING FURNITURE CO., LTD.

地址：广东省佛山市高明区富湾镇富湾工业区
Address: FuWan Industrial Area, FuWan Town, GaoMing District, Foshan city, GuangDong, China

联系电话：
国内：0757-88811111 出口：+0086-757-88811055
0757-88819987 +0086-757-89998749
0757-88816808 +0086-757-89998759

Website: www.eagleseating.com
Fax: +0086-757-88816808 Email: juhan@juhan.cn



易高斯登官方微信 (Wechat)



易高斯登
EagleSeating

旗下品牌 Sub-brand



工作 · 养生 · 易高斯登 | Healthy Working, EagleSeating



工作 · 养生 | Healthy Working



工作 · 养生 | Healthy Working



CATALOGUE

目录

1501 系列 Series	005
1503 系列 Series	013
1504 系列 Series	017
1502F 系列 Series	023
1505E-38 系列 Series	027

1301 系列 Series	031
1201 系列 Series	035
0901 系列 Series	037
06001 系列 Series	039
06002 系列 Series	041
0634 系列 Series	043
06004 系列 Series	045
1302 系列 Series	047
1001 系列 Series	049
0902F 系列 Series	051
0801 系列 Series	053
07001F 系列 Series	055

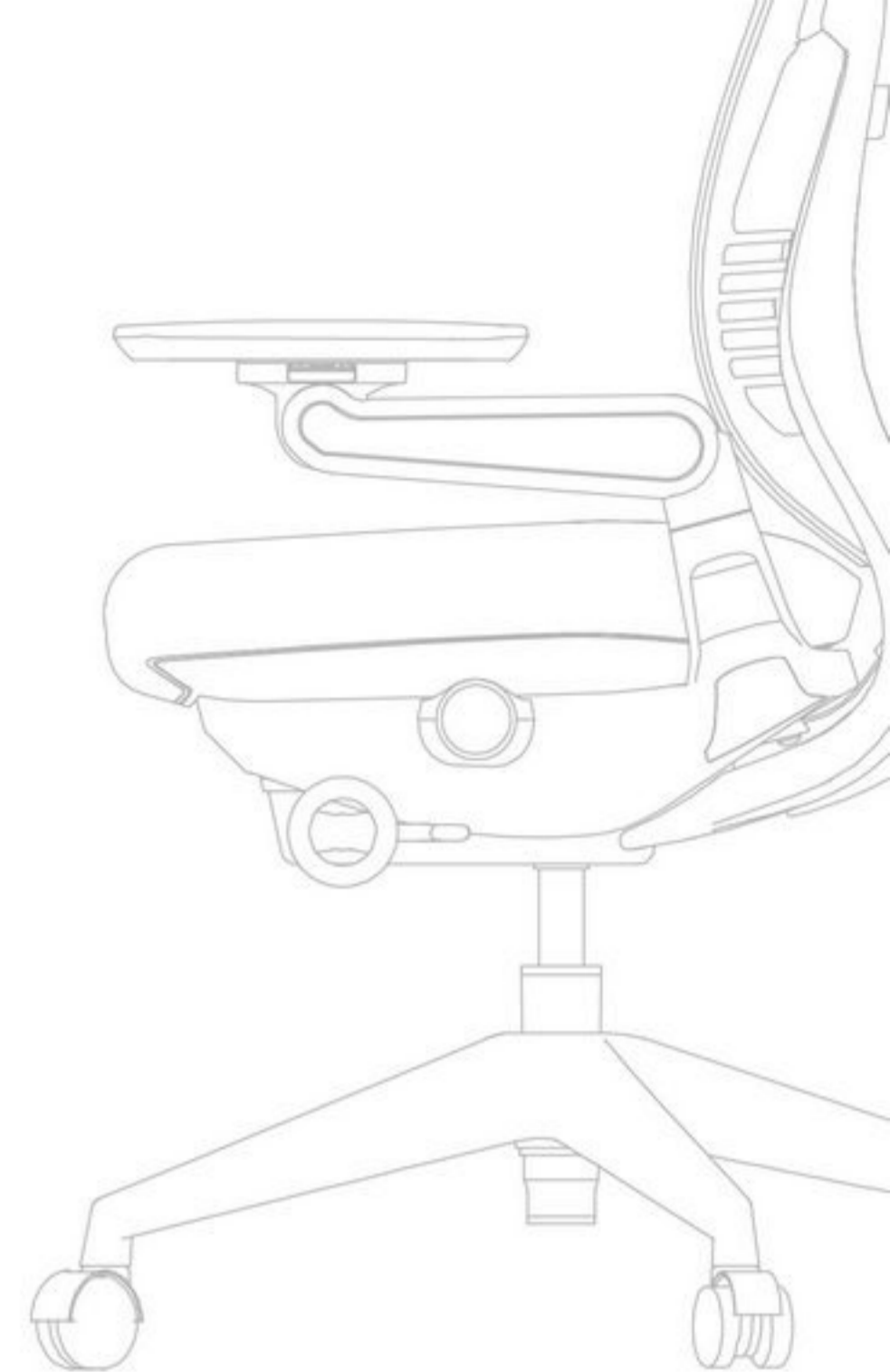

06001F 系列 Series	057
1203E 系列 Series	059
1002E 系列 Series	061
1003E 系列 Series	063
06002F-3 系列 Series	065
E9 E10 系列 Series	067
17 系列 Series	069
0517 P4 系列 Series	071
0517 P5 系列 Series	073
25 系列 Series	075
26 系列 Series	077
31 系列 Series	079
产品说明 Instruction	083



360 度旋转扶手 - 独立支撑 360 度扶手旋转, 扶手面可
前后左右活动, 手臂得到随处支撑。
Unique 360 degree rotary armrest, supporting unlimited variety
of gesture in arm.



整椅前倾控制，在工作状态时保持对身体的支撑
The angle of back and seat is adjustable, it help to support the spine perfectly when working.



背部自由倾斜锁定，靠背腰部在倾斜时向前拱起，保持对腰部的呵护
Multi position lockable tilt, excellently support the lumbar.



靠背能随身体侧旋转时横向移动，减少对腰部的阻力
The backrest is automatically adjusted when the body move horizontally.



3D 扶手面，前后左右活动
The arm pad is adjustable.



座前后移动，调整座深度
With seat slider.



When it move more frequently, it need more kindly support for the body.
移动越频繁，越需要为身体带来更贴家的支撑



1501C-2F24-Y



1501C-2HF24-Y

Adapt to the fashionable office work, beyond your imagination :1501 series is for a variety of body size and seat position in various office work. The backrest close to the waist, upholstered with breathable, durable mesh, the mechanism on backrest automatically adjust the support angle to a perfect support on lumbar. The seat is made of quality molded foam and breathable mesh. One key adjust the angle of back and seat, make perfect posture in working. Unique 360 degree rotary armrest, supporting unlimited variety of gestures in arm. Multi-functional mechanism : seat slider, tilt lock, tilt tension adjustment. Ultra strength PA nylon base (compression affordable>1200KGS). Quality casters and gas lift.

对应最前沿工作方式，超越您的想象：1501系列人体工学椅。1501系列是适用于工作中的各种体型和坐姿。背支撑机构和靠背力活动设计，流水般线条，紧贴人体，靠背在倾仰时腰部向前拱起，保持对腰部的呵护，并提供透气网布或绒布配置。座配高密度定型棉，可前后调整座位深度。特有360度旋转扶手，结合3D扶手面板，无限度承托各种坐姿中的手臂。多功能一体式底盘，提供倾仰锁定和工作状态设置，让椅背在您工作状态中保持对身体的支撑。自主研发模具，PA工程尼龙脚，承重1200KG，气压棒和脚轮符合BIFMA质量标准。



背部倾斜，多角度锁定
Multi-position lockable tilt.



独家设计扶手，上下升降，PU扶手面
Unique armrest design, height adjustment, PU arm pad.



多功能底座，背倾斜多角度锁定，带座滑板，
背倾斜力度调整
Multi-functional mechanism, multi-functional back tilt lock, with
seat slider, back tilt tension adjustment.



后背盖与背板完美结合
Perfect seam in back cover.



背内板尼龙压铸成形，配置定型海绵
One mould injection PA nylon plate, upholstered moulded
foam inside.



1503B-2P21-A

1503C-2P21-A

1503B-2P13-B

1503C-2P13-B

Liberate the burden in spine, to achieve the most high-end comfort: 1503 series. Unique waist support design in backrest, it is a one mould injection reinforced plastic board inside, upholstered with molded foam, finished by faux leather or fabric. the contoured seat, thick molded foam seat upholstered with faux leather or fabric, offering the wonderful feel when seating. Two kinds of armrests: one is one mould injection strong PU armrest, another is height adjustable heavy duty armrest. Two kinds of controls: simple control and multi-functional control. grey powder coated PA nylon base (compression affordable>1200KGS). Good quality gas lift and caster. High back chair and mid back chair for options.

解放脊柱负担，实现高端、舒适、休闲的座椅：1503 系列。独特腰围包裹靠背设计，靠背内板是一模成型的加强结构，承受力 140KG，面料可配皮革或绒布，靠背和座均是高密度定型海绵，座 W 型凹型设计，厚实舒适，减轻久坐引起的不适。扶手两种规格可选：一种是 PU 固定扶手，一种是可升降扶手。两种底盘：无级锁定底盘和多功能底盘。自主研发模具，PA 工程尼龙脚，灰色烤漆，承重 1200KG，气压棒和脚轮符合 BIFMA 质量标准。1503 有大班椅和中班椅配置。



背部倾斜，多角度锁定
Multi-position lockable tilt.



上下升降扶手，PU扶手面
Height adjustment armrest, PU arm pad.



带座滑板，座垫前后移动，调整座深度
With seat slider.



后背盖与背板完美结合
Perfect seam in back cover.



背内板尼龙压铸成形，配置定型海绵
One mould injection PA nylon plate,
upholstered moulded foam inside.





1504B-2P15-A



1504C-2P15-A



1504B-2P15-B



1504C-2P15-B

Modern European style office chair: 1504 series. Backrest is made of faux leather or durable mesh, a reinforced PA plastic board upholstered molded foam inside.(safe and environmental friendly).The shape of back kindly support spine. The seat is made of quality molded foam upholstered faux leather or fabric. Two kinds armrests: fixed armrest and height adjustment armrest. The mechanism pass BIFMA test, is of high quality, optional seat slider. High profile PA nylon base(affordable compression>1200KGS). Quality gas lift and caster. High back chair, mid back chair for options.

现代风格座椅 1504系列。靠背内板是一模成型的加强结构,承受力140KG,靠背造型自由支撑脊柱。靠背和座均是高密度定型海绵,面料羔羊皮或小菱格透气网布。两种扶手选择:固定扶手和上下升降扶手,白色或灰色喷漆。自主研发模具,PA工程尼龙脚,承重1200KG,气压棒和脚轮符合BIFMA质量标准。1504款有大班椅,中班椅配置。



无级锁定，靠背多角度倾仰
Multi-position lockable tilt.



扶手上下升降，PU 扶手面
Height adjustment armrest, PU arm pad.



模拟人体腰部曲线设计
Unique back design to support lumbar.



1502F-2P20-A

1502F-2P22-B

Improve the efficiency in office work, high-quality staff chair : 1502F series. Unique back shape to support spine, strong PA nylon back frame, upholstered with breathable, durable mesh. Up&down armrest, PU arm pad(compression affordable>140KGS). Seat is made of quality molded foam and breathable fabric. Functional control, strong PA nylon base(compression>1200KGS), quality gas lift and caster.

提高工作效率的高品质职员椅：1502F 系列。独特护腰靠背形状，PA 工程尼龙背框，配透气大菱格网布。上下升降扶手，PU 扶手面（扶手垂直承重 140KG）。座为高密度定型海绵，配透气小菱格网布。简易操作底盘，自主研发模具，PA 工程尼龙脚，承重 1200KG，气压棒和脚轮符合 BIFMA 质量标准。



堆叠，节省存放空间
Stackable, save space.



1505E-38A



1505E-38B

Modern, dynamic visitor chair: 1505E-38 series. The back is made of strong plastic (optional white or black), the seat is made of quality foam upholstered with breathable mesh (optional different colors). Powder coated A3 steel bracket (optional Grey or silver). One mould injection strong PA armrest.

现代动感的会议椅：1505E-38 系列。椅背为 PA 工程尼龙料（黑白可选），座为优质海绵配透气小菱格网布（颜色可选）。A3 钢喷涂脚架（潮翠灰，闪光银）。一模成型 PA 工程尼龙料扶手。



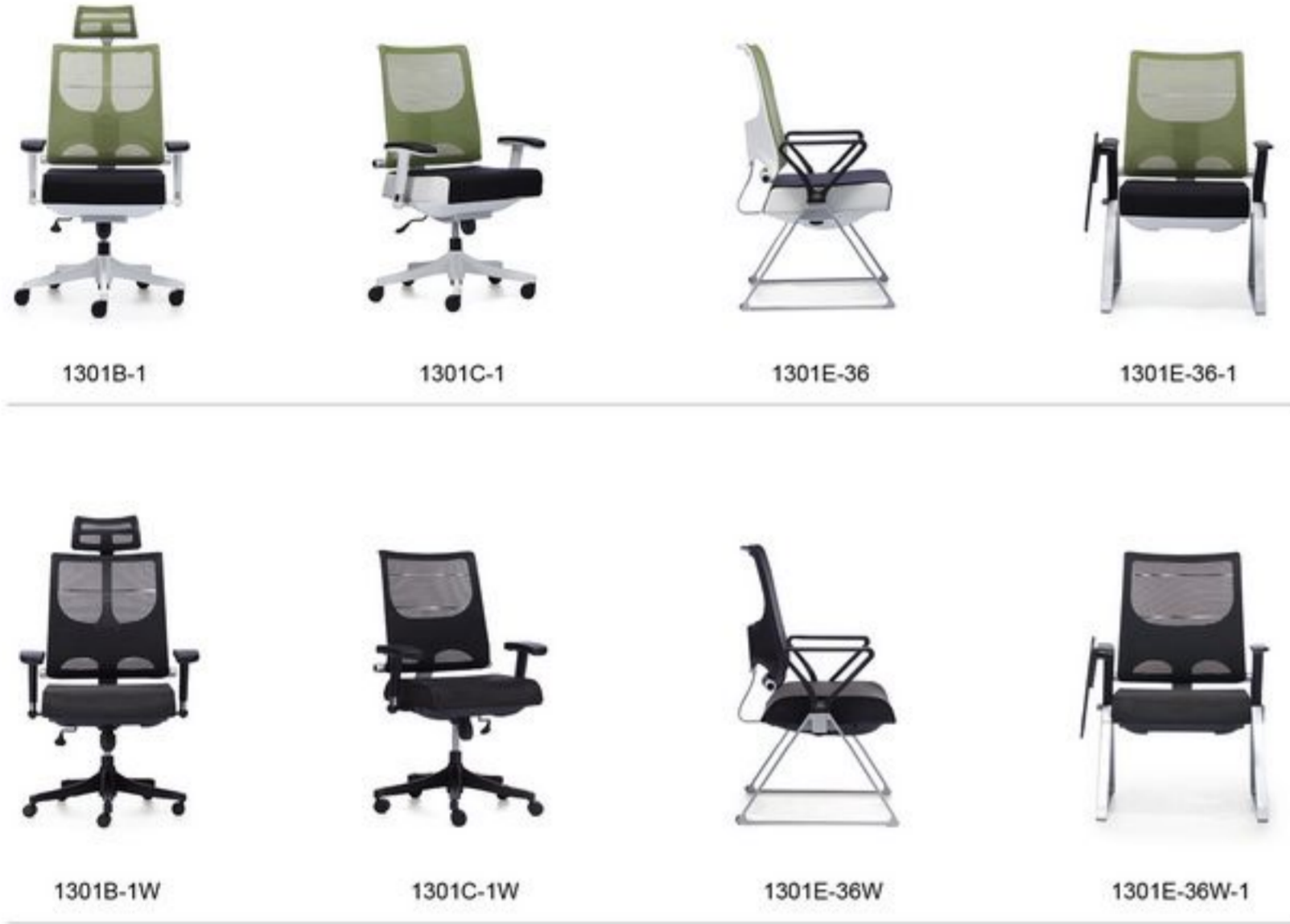

Reducing the fatigue which is caused by prolonged seating- 1301 series. The backrest of 1301 series is made of excellent PA nylon, upholstered durable elastic mesh (optional extra faux leather cover), the backrest can be adjusted up & down, forward & backward, make the posture fit to every body sizes. Three kinds of seats: thick molded foam upholstered with durable fabric(1301), thick molded upholstered with excellent faux leather(1301H), imported high elastic mesh(1301W). Getting more comfort on seating. Height&Angle adjustable armrest, PU arm pad. Two kinds control : Simple tilt lock control or Multi-functional control. reinforced PA nylon base. Silver A3 steel bracket in meeting chair. Quality gas lift and caster. High back chair, mid back chair, conference chair for options.

减少久坐带来的身体疲劳——1301系列。1301系列背框为PA工程尼龙配上耐用弹力网布。靠背可以上下升降调整背部支撑位置，可以前后调整，适合任何身高体型的办公人士。座为厚实的定型海绵加上柔软的绒布，座感更舒适。3D扶手可上下升降，PU扶手面可前后和角度调整。底盘是二段式锁定机能。自主研发模具，PA工程尼龙脚。A3钢会议椅架子。气压棒和脚轮符合BIFMA质量标准。1301系列有大班椅，中班椅，会议椅。

头枕上下升降、翻转
Height&Angle adjustable headrest.

靠背上下升降，白色喷漆
Height adjustable backrest.

靠背前后活动
Forward&backward backrest.

座背同步倾斜
Lockable tilt.

3D扶手上下升降，PU扶手面左右前后活动
3D height adjustable armrest,adjustable PU arm pad.

座垫加厚定型海绵
Thick molded foam seat.

会议架带连接扣
Connector in conference chair.

会议架带移动滑轮
With wheels in conference chair.



1301B-1H



1301C-1H



1301E-36H



1301E-36H-1



Reducing the fatigue which is caused by prolonged seating- 1301 series. The backrest of 1301 series is made of excellent PA nylon, upholstered durable elastic mesh (optional extra faux leather cover), the backrest can be adjusted up & down, forward & backward, make the posture fit to every body sizes. Three kinds of seats: thick molded foam upholstered with durable fabric(1301), thick molded upholstered with excellent faux leather(1301H), imported high elastic mesh(1301W). Getting more comfort on seating. Height&Angle adjustable armrest, PU armpad. Two kinds control : Simple tilt lock control or Multi-functional control. reinforced PA nylon base. Silver A3 steel bracket in meeting chair. Quality gas lift and caster. High back chair, Mid back chair, meeting chair for options.

减少久坐带来的身体疲劳——1301系列。1301系列背框为PA工程尼龙配上耐用弹力网布。靠背可以上下升降调整背部支撑位置，可以前后调整，适合任何身高体型的办公人士。座为厚实的定型海绵上柔软的绒布，座感更舒适。3D扶手可上下升降，PU扶手面可前后和角度调整。底盘是二段式锁定机能。自主研发模具，铸铝合金五星脚。A3钢会议椅架子。气压棒和脚轮符合BIFMA质量标准。1301系列靠背可加皮套，座可用皮革，更显高档大方。1301系列有大班椅，中班椅，会议椅。



扶手独家设计，上下升降，PU扶手面
Unique armrest design, up&down, PU arm pad.



倾仰锁定功能底盘机构
Lockable tilt mechanism.



1201 | 系列 Series



1201B-1



1201B-1H



1202B-1H



1202B-1H

Reclining office chair-1201, 1202.backrest are made of quality engineering plastic, or upholstered breathable mesh, optional faux leather cover. with Height adjustment headrest, there are five points angle adjustment in backrest, functional control with seat slider. Functional armrest. The seat can be unfolded, then it is a lounge chair. King size reinforced base. when you are working, it is a good office chair, when you want to relax, it is a perfect lounge chair.

可以变身躺椅的办公椅——1201、1202系列。背框为PA工程尼龙料，可配透气网布、西皮，可加软体皮革。带高度调整头枕，背框独立倾仰、角度五段式锁定。座前后滑动，扶手上下升降，PU扶手面可前后移动。座垫可翻开变为脚踏，办公的时候是一把舒适的椅子，休息的时候，能变身为一张很好的休息沙发。配加大钢制五星脚。



头枕上下升降，翻转
Height&Angle adjustable headrest.



靠背分段向后倾斜
Back tilt angle adjustment.



扶手上下升降，PU扶手面，可前后活动
Height adjustable armrest, PU arm pad, forward&backward.



座垫定型海绵，可前后滑动，座板能打开
Molded foam seat, with seat slider.



背框及背板设计，可选择透气网面或带海绵背
Unique backrest design, optional durable mesh upholstered or faux leather upholstered.



0901B-2W



0901C-2W



0901E-28W



0901B-2



0901C-2



0901E-28



0901B-2H



0901C-2H



0901E-28H

Heavy duty aluminum frame and light feeling mesh combined, high grade space: 0901 series. Curve design on backrest, up and down adjustment to support spine, suitable for different size bodies in office. Strong PA nylon back frame and seat frame. Height&Angle adjustable armrest. Functional mechanism, wire control, Optional seat slider. High profile polished aluminum base(affordable compression>1300KG), A3 steel cantilever in conference chair. Quality caster and gas lift(Pass BIFMA test). Optional high back chair, mid back chair and conference chair. Optional faux leather or high elastic mesh in back. Optional high elastic mesh or breathable mesh or faux leather in seat.

厚重的铝制结构和轻薄质感的网布结合，演绎高品质空间：0901系列。弧形的靠背设计，可上下调整靠背支撑位置，符合各种体型的办公需求。PA工程尼龙背框和座框，靠背和座可配皮和高弹力网布。3D扶手可上下左右前后调整。多功能底座，线控操作，可调整座深度。自主研发模具，铸铝合金五星脚，A3钢会议椅架子，气压棒和脚轮符合BIFMA质量标准。有大班椅，中班椅和会议椅配置。



头枕上下升降，翻转
Height&Angle adjustment.



靠背上下升降
Height adjustable backrest.



靠背多段倾仰锁定，背倾仰
松紧调节
Multi-position lockable tilt, back
tension adjustment.



3D扶手上下升降，宽度调整，
扶手前后左右活动
3D armrest,height adjustment,width
adjustment,forward&backward.



座垫前后移动，调整深度
With seat slider.





06001B-2P5



06001C-2P5



06001E-19



头枕上下升降、翻转
Height&Angle adjustment.



靠背多段倾仰锁定
Multi-position lockable tilt.



3D 扶手上下升降，
扶手面左右活动
Height adjustable 3D armrest
arm pad adjustment horizontally.



06001B-2P6



06001C-2P6



06001C-2HP19



06001C-2P19-C



06001C-2P19-T



06001E-19-C



腰靠上下调整
Height adjustment in lumbar bag.

Regular wide and thick office chair: 06001 series. The appearance of 06001 series is regular. Square strong PA back upholstered with imported high elastic mesh, optional adjustable lumbar bag. Square seat is made of high density foam with breathable sandwich fabric. Strong aluminum back bar connecting, offer safe and comfortable seating. Functional armrest. Multi-functional mechanism, five points tilt lock. Polish aluminum base(affordable compression>1200KG).A3 steel cantilever in conference chair. Have high back chair, mid back chair ,conference chair for options.

端正宽厚的办公用椅：06001系列。06001系列没有花巧的外表，给你方正、硬朗的办公气息。PA工程尼龙背框配进口高弹力网布，可调节腰靠。方正的座垫为高密度海绵。结实的铸铝合金连接座背，提供安全舒适的座感。上下升降，扶手面前后活动和角度调整的3D扶手。多段锁定多功能底座。自主研发模具，铸铝合金五星脚（可选PA工程尼龙脚），A3钢会议椅架子，气压棒和脚轮符合BIFMA质量标准。有大班椅，中班椅和会议椅配置。





06002B-2WP5B



06002B-2WP5C



06002C-2WP5



06002E-20W



06002B-2P5B



06002B-2P5C



06002C-2P5



06002E-19



06002B-2HP5B



06002B-2HP5C



06002C-2HP5



06002E-19H

Excellent Contoured design: 06002 series. Contoured shape in back and seat, it let you feel more free in any workspace. PA back frame (upholstered imported high elastic mesh or quality faux leather), PA seat frame (upholstered imported high elastic mesh or molded foam with quality faux leather). Height adjustable headrest, adjustable lumbar bag. Multi-functional armrest, multi-functional control, high profile aluminum base (optional PA nylon base), silver A3 steel cantilever on conference chair. Good quality caster and gas lift. High back chair, mid back chair, conference chair for options.

极具线条感的设计之美：06002系列。靠背和座垫采用瀑状线条，配上圆润的扶手和五星脚设计，在任何工作空间都能得到更好的舒适感受。PA工程尼龙背框和座框，靠背和座可配皮和高弹力网布。带升降头枕，可调节腰靠。3D扶手，可上下升降，左右调节。多功能底盘可带座滑板，调整座深度。自主研发模具，铸铝合金五星脚（可选PA工程尼龙脚）。A3钢会议椅架子。气压棒和脚轮符合BIFMA质量标准。有大班椅，中班椅和会议椅配置。



头枕上下升降，翻转
Height & Angle adjustment.

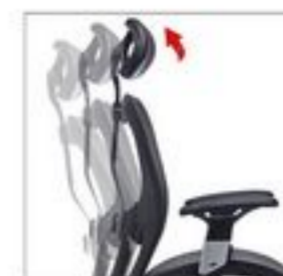

靠背多段倾斜锁定
Multi-position lockable tilt.



腰靠前后调整
Adjustable lumbar bag.



3D扶手上下升降，扶手前后移动
Height adjustable 3D armrest and forward & backward arm pad.



座深度调整
With seat slider.





0634 系列 Series



0634B-2P5B



0634B-2P5C



0634C-2P5



0634E-16



0634B-2WP5B



0634B-2WP5C



0634C-2WP5



0634E-18W

Classic ,Steady office chair: 0634 series. PA nylon back upholstered high elastic imported mesh, seat are made of molded foam upholstered with breathable sandwich fabric or imported high elastic mesh(0634B-2WP5B(C), 0634C-2WP5, 0634E-18W). Extreme strong aluminum back bar connect back and seat. Constructing safe and comfortable seat. Functional five positions back tilt lock mechanism, back tilt tension adjustment, with seat slider, 0634B-2WP5B(C),0634C-2WP5) Reinforced aluminum base(affordable compression>1200KGS), A3 steel cantilever in conference chair. Quality caster and Gas lift(Pass BIMFA test). High back chair, mid back chair, conference chair for options .

经典稳重的办公椅：0634 系列。背网布为进口高弹力网布，座为高密度定型海绵配透气三文治网布（可配高弹力进口网布）。PA 工程尼龙料外框和座外框，高强度铸铝合金连接，构建舒适安全感。多功能多段锁定底盘，背倾仰力度调整，可带座滑板，调整座深度。自主研发模具，铸铝合金五星脚。A3 钢会议椅架子。气压棒和脚轮符合 BIMFA 质量标准。有大班椅，中班椅和会议椅配置。



头枕上下升降、翻转
Height&Angle adjustable
headrest.

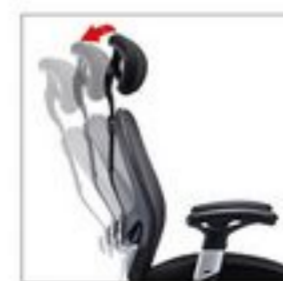

背靠多段倾仰锁定，
背倾仰力度调节
Multi-position lockable tilt, back
tension adjustment.



腰靠前后调整
Forward&backward lumbar bag.



扶手上下升降，宽度调整
Height adjustable armrest, Width
adjustment.



座前后移动，调整座深度
With seat slider.



06004B-2P5C



06004C-2P5



06004E-19



06004C-2WP5



06004E-20W



06004C-2HP5



06004E-19H



06004C-2P13



06004E-19-B

Comfort, Dynamic computer chair: 06004 series. Great and strong back shape with adjustable lumbar bag, the backrest is made of high elastic mesh or quality faux leather. concave seat upholstered high elastic mesh or molded foam with faux leather. Multi- functional mechanism, five points tilt lock, back tilt tension adjustment. Reinforced PA nylon base (Affordable compress>1200KGS). A3 steel cantilever in conference chair. High back chair , mid back chair, conference chair for options.

动感舒适的办公椅：06004 系列。优良的背部支撑带可调节腰靠，背网布为进口高弹力网布，座为高密度定型绵配透气三文治网布（可配皮革）。PA 工程尼龙料外框和座外框，悬臂固定扶手。多功能多段锁定底盘，背倾仰力度调整，可带座滑板，调整座深度。自主研发模具，PA 工程尼龙脚（通过 1200KGS 静压测试），A3 钢会议椅架子。气压棒和脚轮符合 BIFMA 质量标准。有大班椅，中班椅和会议椅配置。





1302F-1



1302F-1



1302E-34



1302E-34

Massage the back: 1302 series. Back is curved design, Comfortably support the lumbar. Back and seat are made of engineering plastic. Moveable backrest, reinforced PA base. A3 steel cantilever in meeting chair. Staff chair and meeting chair for options.

紧贴靠背的职员椅: 1302 系列。背为特别弧度设计, 可舒适地包裹靠背。座和背为 PA 工程尼龙料制作, 背可前后移动。自主研发模具, PA 尼龙五星脚, A3 钢脚架 (会议椅)。1302 系列配有职员椅和会议椅配置。



靠背前后活动
Forward&backward backrest



座垫掀起堆叠
Seat can be folded, stacking horizontally



1001C-2

1001F-2

1001F-2

1001F-2

Comfortable modern typist chair: 1001 series. One mould injected PA seat and back connection., the backrest, connection, Armrest are made of PA nylon. Back is upholstered with elastic mesh, seat is upholstered with molded foam and durable fabric. Wire handle control: up and down, synchronous tilt mechanism. Up&Down armrest, can tilting backward. PA66 reinforced nylon base. Quality caster and Gas lift.

现代舒适灵动的职员椅：1001 系列。一体式坐位与背框连接，独特设计，PA 工程尼龙料一模压铸成型。线控升降和倾仰底盘。自主研发模具，可升降和后仰的扶手，PA 工程尼龙脚。气压棒和脚轮符合 BIFMA 质量标准。



靠背倾仰
Tiltable backrest.



扶手向后翻转
Tilt adjustment armrest.



扶手上下升降，面板前后活动
Height adjustable armrest,
forward&backward arm pad.



0902F 系列 Series



0902F-2P13



0902FE-29

Extreme strength and practical task chair: 0902F series. Good quality PA nylon back and heavy duty aluminum corner, back upholstered elastic mesh, seat is made of molded foam upholstered with breathable fabric. Infinite tilt lock, multi-functional control. Up&Down armrest(affordable compression>90KGS). Reinforced PA nylon base (Affordable compression >1200 KGS). Silver A3 steel cantilever in meeting chair. Quality caster and gas lift. Task chair and meeting chair for options.

极度牢固和实用的职员椅 0902F系列。PA工程尼龙背框和铝合金角码，靠背高弹力网布与座包高密度海绵的结合，拥有舒适的座感。可任意倾仰锁定的无极底座。扶手承重 140KG。自主研发模具，PA工程尼龙脚（通过 1200KG 静压测试）。A3 钢会议椅架子。气压棒和脚轮符合 BIFMA 质量标准。0902 系列配有职员椅和会议椅。



0801F-2P13M



0801F-2P13



0801E-25



0801H-26



0801H-26S



0801H-27



0801H-27S

Inspiring your enthusiasm: 0801 series. Perfect curve back, "Y" shape back support, quality Engineering Plastics back frame. Upholstered soft knit mesh. Seat is made of molded foam with elastic fabric mesh. Height adjustment armrest (ok for compression 90KGS), PU arm pad. Multi-Functional mechanism for task chair: infinite tilt lock, back tilt tension adjustment. exclusive polish aluminum base.(OK for 1200KGS compression).A3 silver steel bracket in conference chair and meeting chair. 0801 series is of high quality, and price is competitive. Task chair, meeting chair, conference chair for options.

激发工作热情的办公椅：0801系列。完美的靠背曲线，PP工程料背框，Y型后背加固支持，配上柔软的网布织物。座为高密度定型海绵透气网布。扶手可升降（垂直承重90kgs），配PU扶手面。功能底座可无级倾仰锁定，靠背倾仰松紧调节。自主研发模具，铸铝合金五星脚（静压1200KG）。A3钢会议椅架子。气压棒和脚轮符合BIFMA质量标准。0801系列拥有优秀的品质，舒适的座感，而性价比非常高。0801系列有职员椅，会议椅，培训椅。





07001F-1P8



07001FE-23



07001FE-17



07001FE-21

Competitive "little Fang": 07001F series. The backrest of 07001F is made of quality engineering plastic upholstered with durable mesh. Seat is made of high density foam and breathable mesh. Height adjustable armrest, simple lock control, the reinforced PA nylon base is made by ES own mould. A3 steel bracket in meeting chairs. Casters and gas lift are of high quality (pass BIFMA test). Task chair, meeting chair, conference chair for options.

实惠的“小方”：07001F系列。07001F系列靠背是由PA工程尼龙料成型，配上透气网布。座为高密度海绵加上耐用网布。可升降扶手，一段锁定底座。自主研发模具，PA工程尼龙脚。A3钢会议椅架子。气压棒和脚轮符合BIFMA质量标准。07001F系列有职员椅，会议椅，班前椅。





06001F-2P6



06001FE-24



06001FE-15



06001FE-22

Smart ,practical task chair: 06001F series. The concave design on seat make you feel comfortable, quality foam upholstered breathable mesh . Round back is made of PA nylon upholstered with mesh. Height adjustable armrest, simple control. Strong PA nylon base .A3 steel bracket in meeting chairs. Task chair, conference chair, meeting chair for options.

灵巧实用的职员椅“小圆”：06001F 系列。06001F 系列应用高密度海绵配透气网布，获得舒适的座感。小巧圆顺的靠背由 PA 工程尼龙料配上透气网布，带可调整腰靠。扶手可以升降，同步倾斜底盘。自主研发模具，PA 工程尼龙五星脚。A3 钢会议椅架子。06001F 系列有职员椅，会议椅，班前椅。



1203E 系列 Series



1203E-33



1203E-33S



1203E-33-1



1203E-33



1203E-33S



1203E-33-1



1203E-33S-1

From meeting room to studio, it is suitable: 1203E series. strong PA nylon backrest upholstered with elastic mesh, nice lumbar support design. Quality molded foam upholstered durable fabric mesh. Heavy duty chair steel frame (silver or black powder coat), one mould injected PU armrest. Optional tablet, casters in 1203E series.

从一般会议到研讨室都通用的椅子：1203E 系列。PA 工程尼龙背框配高弹力网布，恰到好处的腰部支撑设计。座是优质定型棉网透气网布。厚重的四脚支架，扶手具有中国古典家具线条灵感，PU 材质。1203E 系列配有写字板，脚轮可以供选择。



1002E-31



1002E-31F



1002E-31S



背靠活动
Flexible backrest.



扶手前后活动
Forward&backward arm pad.



1002E-31-1



1002E-31S-1



1002E-31FS-1



座垫掀起, 堆叠
Seat can be folded, stacking horizontally.

Simplicity, modern ergonomic meeting chair: 1002E series. Excellent PA nylon frame, durable elastic mesh upholstered. Molded foam upholstered breathable mesh in seat. The chair bracket is made of A3 steel, forward and backward armrest. The seat can be folded, stacking horizontally. Save stocking space. Two kinds of backrests: fix and flexible .optional caster and tablet. The seat pass BIFMA 136kgs drop test.

简约现代人体工程学会议椅：1002E 系列。PA 工程尼龙背框，结实耐用的高弹力网布。座配定型棉和小梨纹布。整椅支架为结实 A3 钢制造，扶手可前后滑动，座翻起后可横向堆叠，节省堆放空间。靠背有两种方式：固定和可摇动。脚轮和写字板可供选择。通过 BIFMA 136KG 跌落测试。



1003E-32



1003E-32



1003E-32

Simplicity, leisure meeting chair: 1003E. Backrest and seat are made of strong PA nylon. Reinforced structure in seat. chair bracket is made of Excellent A3 steel. Stackable function, save stock space. It can be used in meeting room, or rest area. Optional three colors: black, red, white.

简约休闲会议椅：1003E。靠背和座为PA工程尼龙料，具有树枝展向的镂空设计，A3钢架与扶手一体，自然扭曲而成，淡雅灰喷涂。椅子可堆叠叠起，节省摆放空间。既适用于会议室，也是用于休息区域。颜色有黑，白，红三种可选。





06002F-3



06002F-3



06002F-3



06002F-3

Dual use conference chair: 06002F-3. The 06002F-3 is made of strong PA nylon, chair bracket is A3 steel with chrome finished. One key control : office chair become office table. Fantastic Dual use.

“一箭双雕”的会议椅：06002F-3。06002F-3 椅身由 PP 工程料压注，椅架为电镀 A3 钢。06002F-3 可以一键翻起变成休闲桌，一物两用。



E-9



E-9-1



E-9H



E-9H-1



E-9S



E-9S-1



E-10

wonderful Simplicity design: E9,E10. shine silver powder coat chair frame, upholstered with breathable mesh or soft faux leather, or shine engineering plastic. Armrest is made of strong plastic. Quality foam upholstered mesh, or faux leather, or strong plastic in seat. Optional tablet in E9 series.

简洁设计之美 E9,E10 系列。金属椅架，能配上通透的网布靠背，或柔软舒适的西皮，或明亮的工程塑料。扶手为结实塑料扶手。座垫能配海绵和透气网布，或西皮和塑料。E9 系列可配置写字板。



17B-1



17C-1



17D-1



17E-5



17B-1H



17C-1H



17D-1H



17E-5H

Classic Eames style: 17 series. Back: high tech chrome plated steel frame, a combination of imported elastic mesh or faux leather stitched horizontally to achieve a series of ribs running the width of the chair. Fitted in to the angled frame which is constructed so as to encourage good posture and give firm lumbar support. simple control, polish aluminum armrest. Aluminum base. A3 chrome steel bracket in meeting chair&conference chair. high back chair, mid back chair, conference chair, meeting chair for options.

经典 Eames 风格: 17 系列。电镀框架, 背和座为整块网布或皮质, 背和座的弯位恰到好处, 构建一个好的坐姿, 能给出更好的背部支撑。扶手有铝合金和尼龙两种版本。底盘有两种: 经典底盘和多功能底盘。五星脚有铝合金和 PA 尼龙脚选择。A3 钢会议椅架。17 系列有大班椅, 中班椅, 会议椅, 班前椅配置。



0517B-1TP4



0517C-1TP4



0517D-1T



0517E-5T



0517B-1PP4



0517C-1PP4



0517D-1P



0517E-5P

Classic Eames style: 0517 P4 series. Back : high tech chrome plated steel frame, a combination of faux leathers or elastic mesh stitched horizontally to achieve a series of ribs running the width of the chair. Fitted in to the angled frame which is constructed so as to encourage good posture and give firm lumbar support. simple control. plastic armrest. PA nylon base . A3 chrome steel bracket in meeting chair&conference chair. High back chair, mid back chair, conference chair, meeting chair for options.

经典 Eames 风格：0517 P4 系列。电镀框架，背和座为整块皮革或弹力网布订制，背和座的弯位恰到好处，构建一个好的坐姿，能给出更好的背部支撑。PA 工程尼龙扶手。简易底盘。PA 工程尼龙脚。A3 钢电镀会议椅架。0517 P4 系列有大班椅，中班椅，会议椅，班前椅配置。



0517 P5 | 系列 Series



0517B-1P5



0517C-1P5



0517D-1



0517E-5



0517B-1HP5



0517C-1HP5



0517D-1H



0517E-5H

Classic Eames style: 0517 P5 series. Back: high tech chrome plated steel frame, a combination of faux leather or imported elastic mesh stitched horizontally to achieve a series of ribs running the width of the chair. Fitted in to the angled frame which is constructed so as to encourage good posture and give firm lumbar support. Multi-functional control: Multi back position tilt lock. Polish aluminum armrest. polish aluminum base .A3 chrome steel bracket in meeting chair&Conference chair. High back chair, mid back chair, conference chair, meeting chair for options.

经典 Eames 风格: 0517 P5 系列。电镀框架, 背和座为假块皮革或者进口高弹力网印制, 背和座的弯位恰到好处, 构建一个好的坐姿, 能给出更好的背部支撑。铝合金抛光扶手。多功能底座: 多段倾斜锁定, 背倾斜度调节。铝合金抛光五星脚。A3 钢电镀会议椅架。0517 P5 系列有大班椅, 中班椅, 会议椅, 班前椅配置。



25 系列 Series



25B-1P5



25C-1P5



25E-5

Allow better integration of metal and leather: 25 series. Back : high tech chrome plated steel frame, a combination of real or faux leathers stitched horizontally to achieve a series of ribs running the width of the chair. Fitted in to the angled frame which is constructed so as to encourage good posture and give firm lumbar support. Aluminum polish armrest, multi- functional mechanism, polish aluminum base.A3 chrome steel cantilever in conference chair. High back chair, mid back chair, conference chair for options.

让金属与皮革更好地融合：25 系列。电镀框架，背和座是由一整张皮革及海绵缝合而成，背和座的角度恰到好处，构建一个舒服的坐姿，能给出更好的背部支撑。扶手为铝合金抛光扶手，多功能底座，铝合金抛光脚。A3 钢会议椅架子。25 系列有大班椅，中班椅，会议椅配置。



26B-1P5



26C-1P5



26D-1



26E-5



26B-1HP5



26C-1HP5



26D-1H



26E-5H

Classic high grade metal chair : 26 series. High tech chrome A3 steel back&seat frame, upholstered with durable mesh or faux leather(optional with soft cushion on back and seat). Aluminum armrest, multi-functional mechanism , Aluminum base. A3 chrome steel bracket in meeting chair& conference chair. High back chair, Mid back chair, meeting chair, conference chair for options.

经典高档金属椅：26 系列。电镀 A3 钢背和座框架，可配耐用网布或皮革（座和背可添加软体）。铝合金抛光扶手，多功能底座，铝合金抛光脚。A3 钢电镀会议架。26 系列有大班椅，中班椅，会议椅，班前椅。





31 系列 Series



31B-1



31C-1



31D-1



31E-5

The wonderful blend of Metal, mesh, leather: 31 series. High tech chrome metal frame, aluminum polish armrest, base. The backrest is made of faux leather and mesh, waterfall seat is made by quality molded foam upholstered with faux leather. Multi-functional control, five points tilt lock. A3 chrome steel bracket in meeting chair & conference chair. High back chair, mid back chair, conference chair, meeting chair for options.

金属，网布，皮革的绝妙组合：31系列。电镀金属框架，铝合金抛光扶手，五星脚。靠背由皮革和网布缝制，座高密度海绵配上皮革。多功能多段候仰锁定，A3钢会议椅架。31系列有大班椅，中班椅，会议椅，班前椅配置。



| 工作 · 养生 | Healthy Working |



1501C-2F24-Y
 NW:23.2kgs
 GW:25.5kgs
 MEAS/CTN:73x68x42(cm)

材质:
 PA 塑料, 进口高弹力网布, 定型海棉, 灰色喷漆, 尼龙脚
Material:
 PA nylon, plastic, elastic mesh, molded foam, fabric

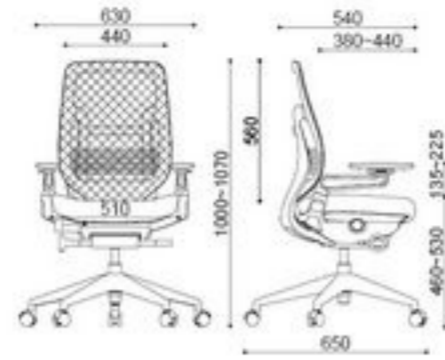

1501C-2HF24-Y
 NW:23.7kgs
 GW:26kgs
 MEAS/CTN:73x68x42(cm)

材质:
 PA 塑料, 小菱格网布, 定型海棉, 灰色喷漆, 尼龙脚
Material:
 PA nylon, plastic, elastic mesh, molded foam, fabric

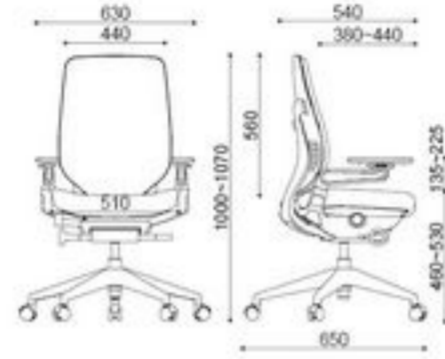

1503B-2P21-A
 NW:24kgs
 GW:26kgs
 MEAS/CTN:83x43x62(cm)

材质:
 PA 塑料, 西皮, 定型海棉, 灰色喷漆, 尼龙脚
Material:
 PA nylon, plastic, molded foam, faux leather

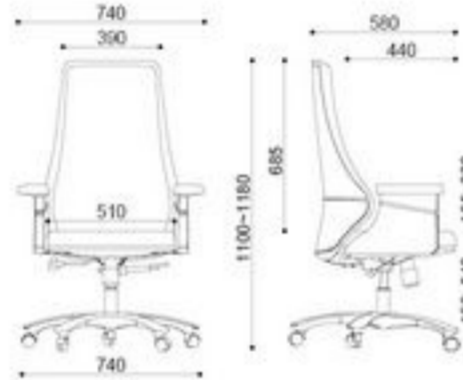

1503C-2P21-A
 NW:22.8kgs
 GW:25kgs
 MEAS/CTN:83x43x62(cm)

材质:
 PA 塑料, 西皮, 定型海棉, 灰色喷漆, 尼龙脚
Material:
 PA nylon, plastic, molded foam, faux leather

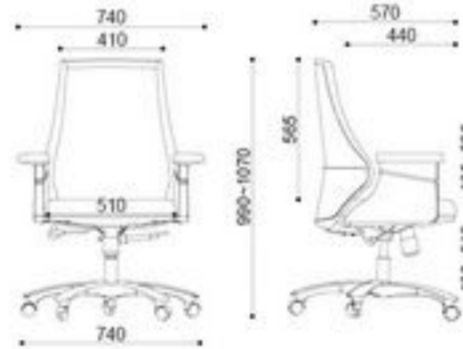

1503B-2P13-B
 NW:21kgs
 GW:23.2kgs
 MEAS/CTN:83x43x62(cm)

材质:
 PA 塑料, 绒布, 定型海棉, 灰色喷漆, 尼龙脚
Material:
 PA nylon, plastic, molded foam, fabric

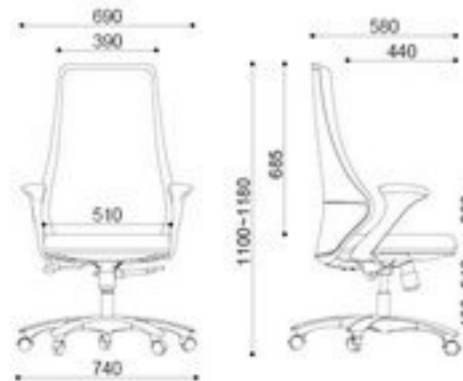

1503C-2P13-B
 NW:19.8kgs
 GW:22kgs
 MEAS/CTN:83x43x62(cm)

材质:
 PA 塑料, 绒布, 定型海棉, 灰色喷漆, 尼龙脚
Material:
 PA nylon, plastic, molded foam, fabric

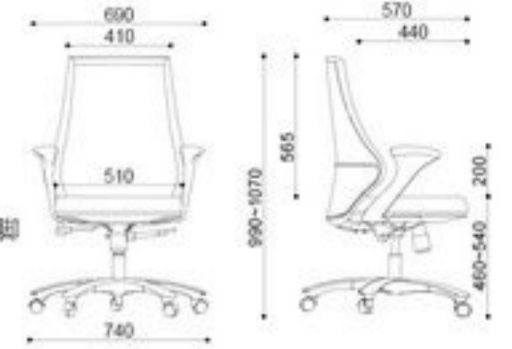

1504B-2P15-A
 NW:21.2kgs
 GW:23.4kgs
 MEAS/CTN:86x34x63.5(cm)

材质:
 PA 塑料, 羔羊西皮, 定型海棉, 灰色喷漆, 尼龙脚
Material:
 PA nylon, plastic, molded foam, faux leather

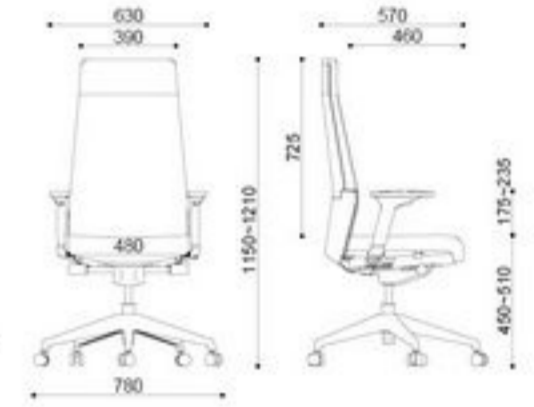

1504C-2P15-A
 NW:20.7kgs
 GW:23kgs
 MEAS/CTN:73x35x63.5(cm)

材质:
 PA 塑料, 羔羊西皮, 定型海棉, 灰色喷漆, 尼龙脚
Material:
 PA nylon, plastic, molded foam, faux leather

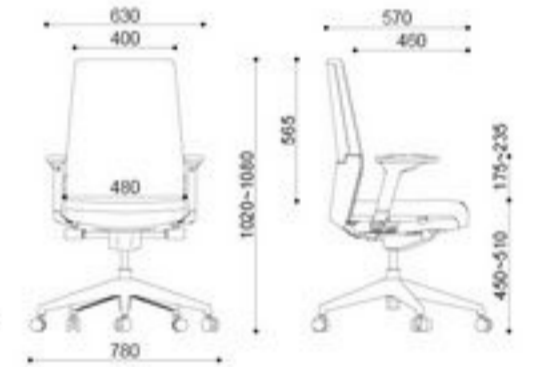

1504B-2P15-B
 NW:21.7kgs
 GW:23.9kgs
 MEAS/CTN:86x34x63.5(cm)

材质:
 PA 塑料, 小菱格网布, 定型海棉, 白色喷漆, 尼龙脚
Material:
 PA nylon, plastic, molded foam, fabric

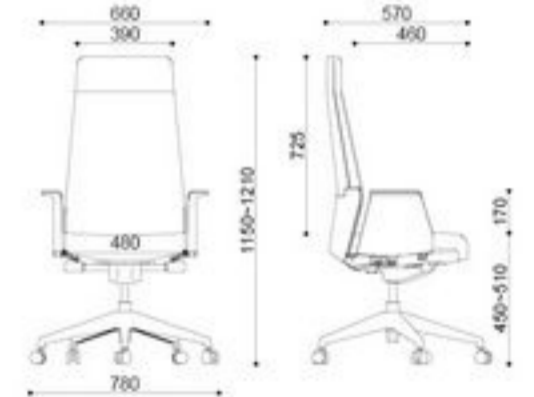

1504C-2P15-B
 NW:21kgs
 GW:23.2kgs
 MEAS/CTN:73x35x63.5(cm)

材质:
 PA 塑料, 小菱格网布, 定型海棉, 白色喷漆, 尼龙脚
Material:
 PA nylon, plastic, molded foam, fabric

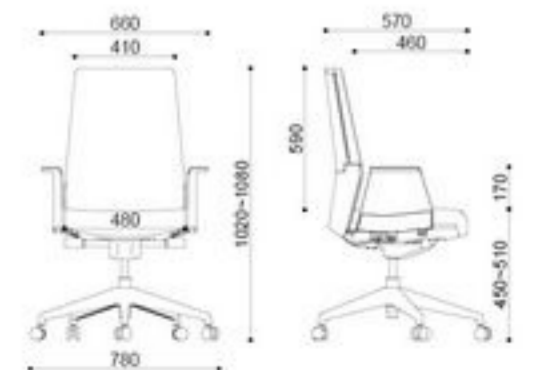



1502F-2P20-A
 NW:15.2kgs
 GW:17.5kgs
 MEAS/CTN:67.5x35x60(cm)

材质:
 PA 塑料, 网布, 定型海棉, 白色喷漆, 尼龙脚
Material:
 PA nylon,plastic,molded foam,elastic mesh,fabric

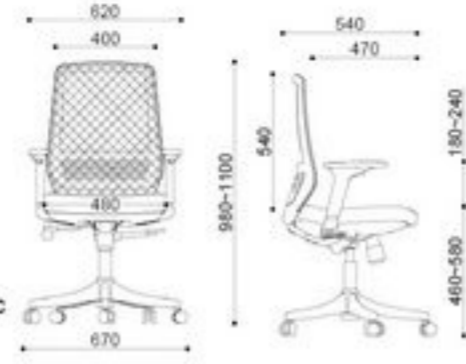

1502F-2P22-B
 NW:14kgs
 GW:16kgs
 MEAS/CTN:67.5x35x60(cm)

材质:
 PA 塑料, 网布, 定型海棉, 尼龙脚
Material:
 PA nylon,plastic,molded foam,elastic mesh,fabric



1505E-38A
1505E-38B
 NW:12kgs/2pcs
 GW:13.8kgs/2pcs
 MEAS/CTN:68x50x56(cm)
 PACKING:2pcs/CTN

材质:
 PA 塑料, A3 钢架, 网布, 海绵, 尼龙脚
Material:
 PA nylon,plastic,molded foam,fabric

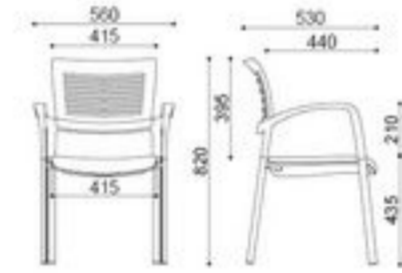

1301B-1H
 NW:24.3kgs
 GW:26.3kgs
 MEAS/2CTN:70x120x60(cm)
 PACKING:1pcs/CTN

材质:
 PA 塑料, 网布, 西皮, 定型海棉, 铝合金脚
Material:
 PA nylon,elastic mesh,molded foam,faux leather,plastic,Aluminum

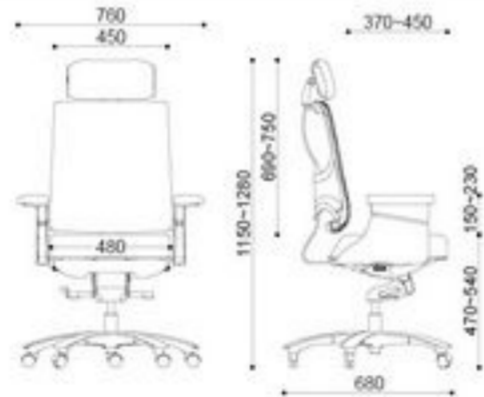

1301C-1H
 NW:23.4kgs
 GW:25.4kgs
 MEAS/2CTN:70x120x60(cm)
 PACKING:1pcs/CTN

材质:
 PA 塑料, 网布, 西皮, 定型海棉, 铝合金脚
Material:
 PA nylon,elastic mesh,molded foam,faux leather,plastic,Aluminum

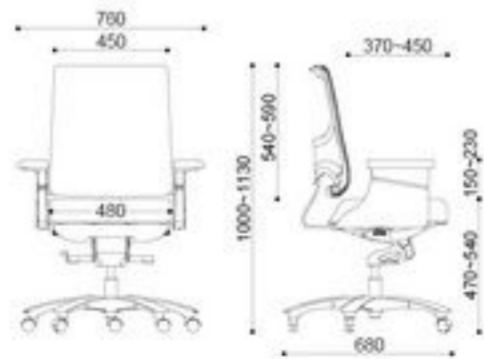

1301E-36H
 NW:18.9kgs
 GW:21.1kgs
 MEAS/2CTN:67x108x59(cm)
 PACKING:1pcs/CTN

材质:
 PA 塑料, A3 钢架, 网布, 西皮, 定型海棉
Material:
 PA nylon,elastic mesh,molded foam,faux leather,plastic,A3 steel



1301E-36H-1
 NW:20.4kgs
 GW:22.6kgs
 MEAS/2CTN:66x54x48(cm)
 PACKING:1pcs/CTN

材质:
 PA 塑料, A3 钢架, 网布, 西皮, 定型海棉
Material:
 PA nylon,elastic mesh,molded foam,faux leather,plastic,A3 steel

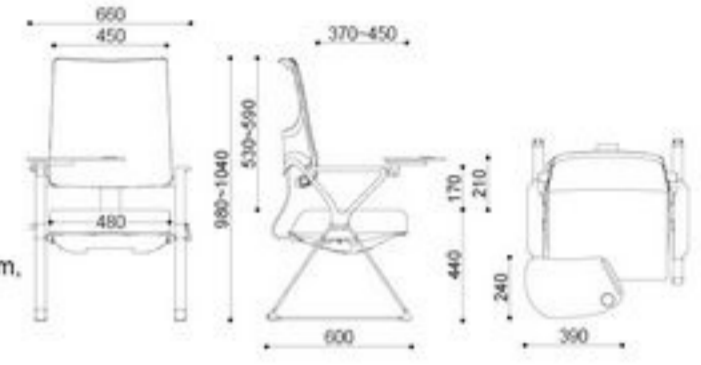

1301B-1
 NW:19.5kgs
 GW:21.5kgs
 MEAS/2CTN:70x120x60(cm)
 PACKING:1pcs/CTN

材质:
 PA 塑料, 网布, 定型海棉, 白色喷漆, 尼龙脚
Material:
 PA nylon,elastic mesh,molded foam,fabric,plastic

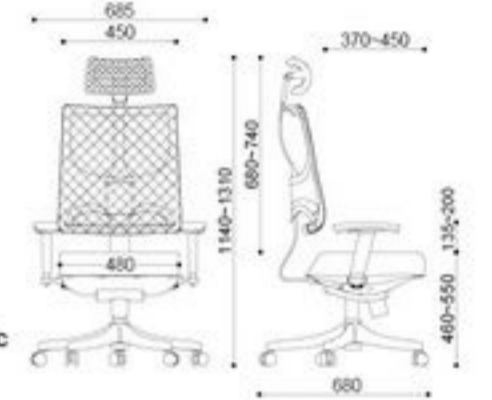

1301C-1
 NW:15.5kgs
 GW:17.5kgs
 MEAS/2CTN:70x120x60(cm)
 PACKING:1pcs/CTN

材质:
 PA 塑料, 网布, 定型海棉, 白色喷漆, 尼龙脚
Material:
 PA nylon,elastic mesh,molded foam,fabric,plastic

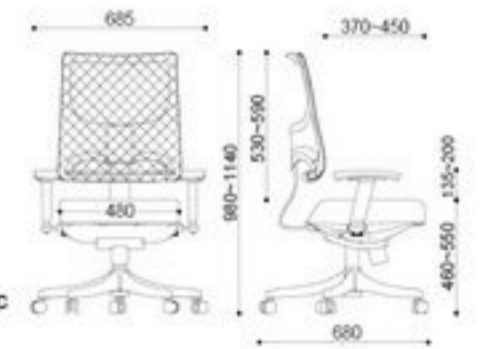

1301E-36
 NW:17.5kgs
 GW:19.7kgs
 MEAS/2CTN:67x108x59(cm)
 PACKING:1pcs/CTN

材质:
 PA 塑料, A3 钢架, 网布, 定型海棉
Material:
 PA nylon,elastic mesh,molded foam,fabric,plastic

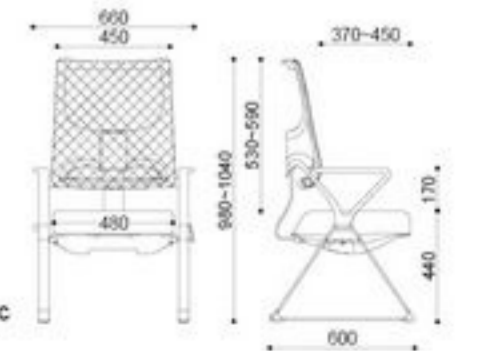



1301E-36-1
 NW:19kgs
 GW:21.2kgs
 MEAS/2CTN:67x108x59(cm)
 PACKING:1pcs/CTN

材质:
 PA 塑料, A3 钢架, 网布, 定型海绵
Material:
 PA nylon,elastic mesh,molded foam,fabric,plastic,A3 steel

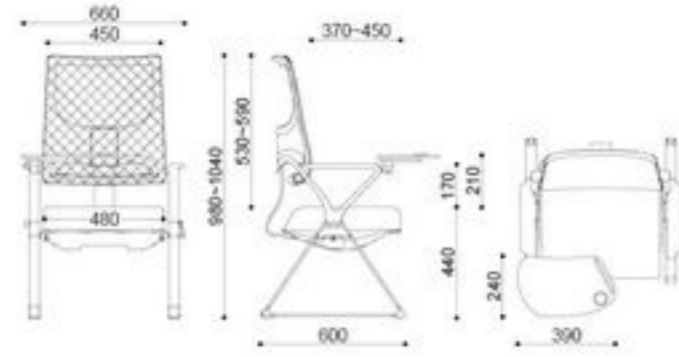

1201B-1
 NW:13.6kgs
 GW:15.8kgs
 MEAS/2CTN:70x120x60(cm)
 PACKING:1pcs/CTN

材质:
 PA 塑料, 网布, 西皮, 定型海绵, 钢脚
Material:
 PA nylon, mesh, sponge,faux leather, plastic,A3 steel

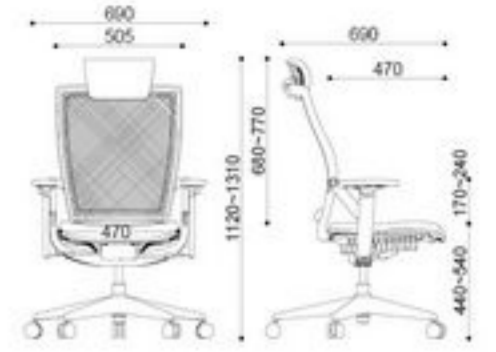

1301B-1W
 NW:19.9kgs
 GW:21.9kgs
 MEAS/2CTN:70x120x60(cm)
 PACKING:1pcs/CTN

材质:
 PA 塑料, 高弹力网布, 定型海绵, 尼龙脚
Material:
 PA nylon,elastic mesh,plastic

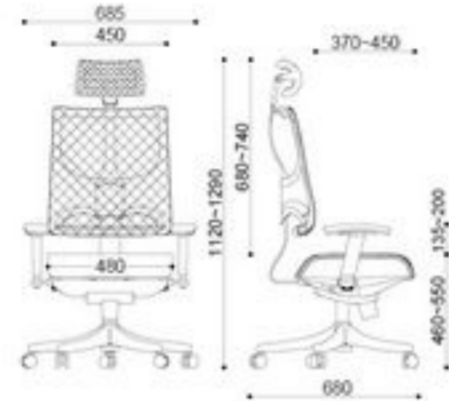

1201B-1H
 NW:13.8kgs
 GW:16kgs
 MEAS/2CTN:70x120x60(cm)
 PACKING:1pcs/CTN

材质:
 PA 塑料, 网布, 西皮, 定型海绵, 钢脚
Material:
 PA nylon, mesh, sponge,faux leather, plastic,A3 steel

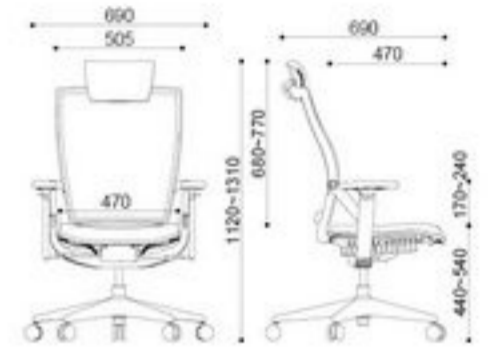

1301C-1W
 NW:18.9kgs
 GW:20.9kgs
 MEAS/2CTN:70x120x60(cm)
 PACKING:1pcs/CTN

材质:
 PA 塑料, 高弹力网布, 定型海绵, 尼龙脚
Material:
 PA nylon,elastic mesh,plastic

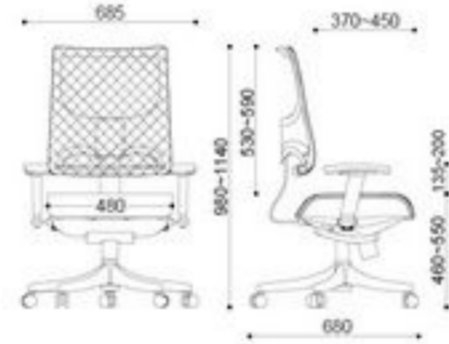

1202B-1H
 NW:15.8kgs
 GW:18kgs
 MEAS/2CTN:70x120x60(cm)
 PACKING:1pcs/CTN

材质:
 PA 塑料, 西皮, 定型海绵, 铝合金脚
Material:
 PA nylon, mesh, sponge,faux leather, plastic,A3 steel

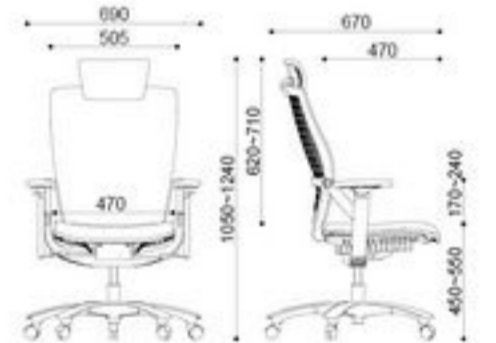

1301E-36W
 NW:19.1kgs
 GW:21.3kgs
 MEAS/2CTN:67x108x59(cm)
 PACKING:1pcs/CTN

材质:
 PA 塑料, A3 钢架, 高弹力网布, 定型海绵
Material:
 PA nylon,elastic mesh,plastic,A3 steel

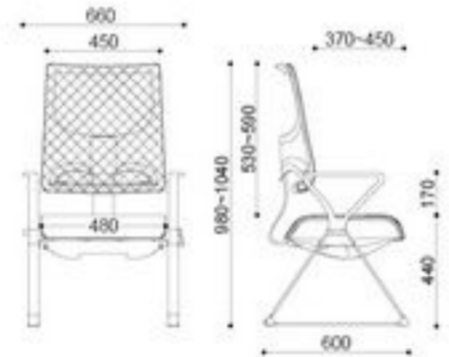

0901B-2W
 NW:20kgs
 GW:22.2kgs
 MEAS/CTN:66x54x68(cm)

材质:
 PA 塑料, 进口高弹力网布, 铝合金脚
Material:
 PA nylon,high elastic mesh,plastic,A3 steel, Aluminum

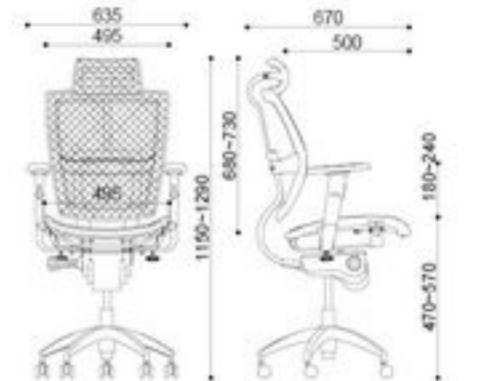

1301E-36W-1
 NW:20.6kgs
 GW:22.8kgs
 MEAS/2CTN:67x108x59(cm)
 PACKING:1pcs/CTN

材质:
 PA 塑料, A3 钢架, 高弹力网布, 定型海绵
Material:
 PA nylon,elastic mesh,plastic,A3 steel

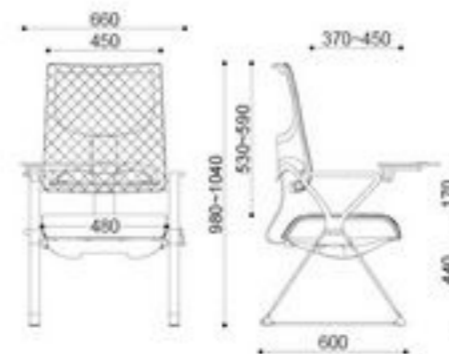

0901C-2W
 NW:18.5kgs
 GW:20.7kgs
 MEAS/CTN:66x54x68(cm)

材质:
 PA 塑料, 进口高弹力网布, 铝合金脚
Material:
 PA nylon,high elastic mesh,plastic,A3 steel, Aluminum

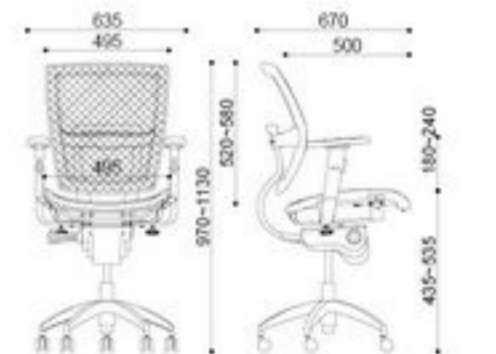



0901E-28W
 NW:15kgs
 GW:17kgs
 MEAS/CTN:65x50x39(cm)

材质:
 PA 塑料, A3 钢架, 进口高弹力网布
Material:
 PA nylon,high elastic mesh,plastic,A3 steel

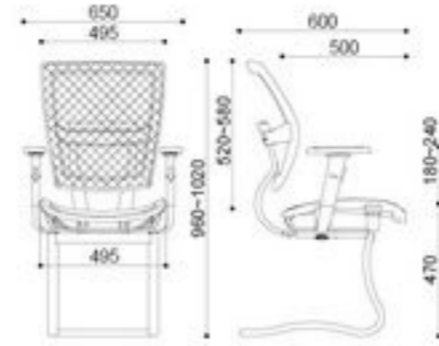

0901C-2H
 NW:19.6kgs
 GW:21.8kgs
 MEAS/CTN:66x54x68(cm)

材质:
 PA 塑料, 西皮, 定型海绵, 铝合金脚
Material:
 PA nylon,high elastic mesh,faux leather, molded foam,plastic, aluminum

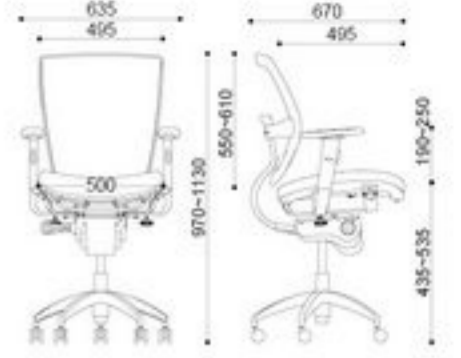

0901B-2
 NW:20.6kgs
 GW:22.8kgs
 MEAS/CTN:66x54x68(cm)

材质:
 PA 塑料, 网布, 定型海绵, 铝合金脚
Material:
 PA nylon,high elastic mesh,fabric,molded foam, plastic,Aluminum

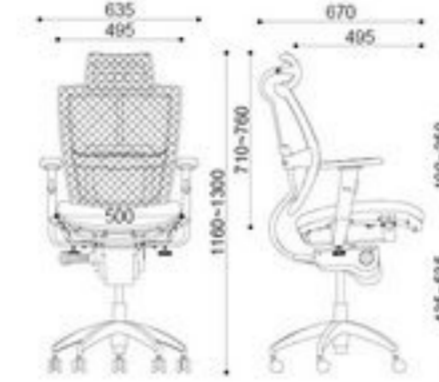

0901E-28H
 NW:16kgs
 GW:18kgs
 MEAS/CTN:65x50x39(cm)

材质:
 PA 塑料, A3 钢架, 西皮, 定型海绵
Material:
 PA nylon,high elastic mesh,faux leather, molded foam,plastic,A3 steel

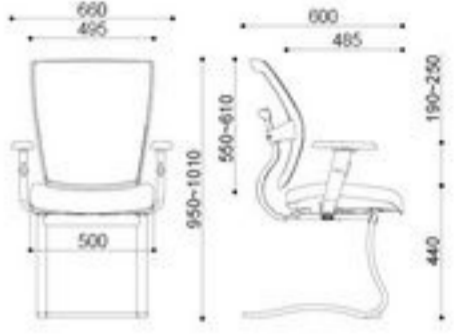

0901C-2
 NW:18.5kgs
 GW:20.7kgs
 MEAS/CTN:66x54x68(cm)

材质:
 PA 塑料, 网布, 定型海绵, 铝合金脚
Material:
 PA nylon,high elastic mesh,fabric,molded foam, plastic,Aluminum

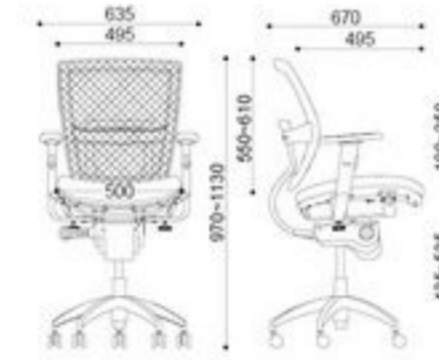

06001B-2P5
 NW:22kgs
 GW:24.2kgs
 MEAS/CTN:70x64x31.5(cm)

材质:
 PA 塑料, 进口高弹力网布, 高密度海绵, 铝合金脚
Material:
 PA nylon,high elastic mesh,sponge,fabric, plastic,Aluminum



0901E-28
 NW:15kgs
 GW:17kgs
 MEAS/CTN:65x50x39(cm)

材质:
 PA 塑料, A3 钢架, 网布, 定型海绵
Material:
 PA nylon,high elastic mesh,fabric,molded foam, plastic,A3 steel

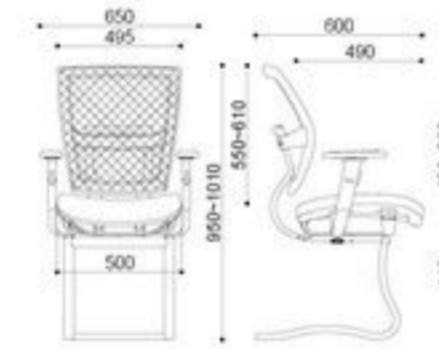

06001C-2P5
 NW:21kgs
 GW:23.2kgs
 MEAS/CTN:70x64x31.5(cm)

材质:
 PA 塑料, 进口高弹力网布, 高密度海绵, 铝合金脚
Material:
 PA nylon,high elastic mesh,sponge,fabric, plastic,Aluminum



0901B-2H
 NW:20.6kgs
 GW:22.8kgs
 MEAS/CTN:66x54x68(cm)

材质:
 PA 塑料, 西皮, 定型海绵, 铝合金脚
Material:
 PA nylon,high elastic mesh,faux leather, molded foam,plastic, aluminum

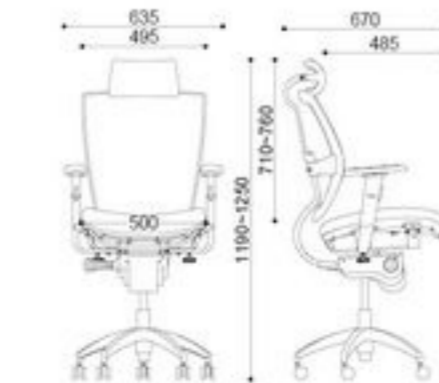

06001E-19
 NW:16.8kgs
 GW:18.8kgs
 MEAS/CTN:69x55x39(cm)

材质:
 PA 塑料, A3 钢架, 进口高弹力网布, 高密度海绵
Material:
 PA nylon,high elastic mesh,sponge,fabric, plastic,Aluminum,A3 steel

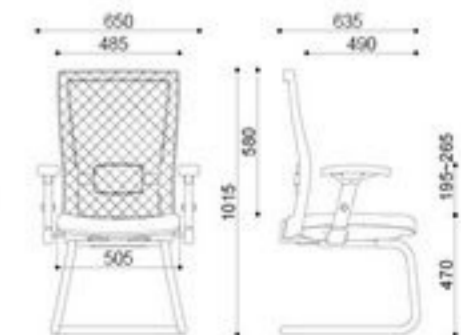



06001B-2P6
 NW:22kgs
 GW:24.2kgs
 MEAS/CTN:70x64x31.5(cm)

材质:
 PA 塑料, 进口高弹力网布, 高密度海绵, 尼龙脚
Material:
 PA nylon,high elastic mesh,sponge,fabric,
 plastic,Aluminum

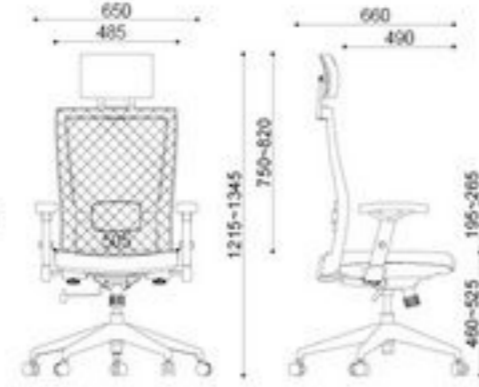

06001C-2P6
 NW:21kgs
 GW:23.2kgs
 MEAS/CTN:70x64x31.5(cm)

材质:
 PA 塑料, 进口高弹力网布, 高密度海绵, 尼龙脚
Material:
 PA nylon,high elastic mesh,sponge,fabric,
 plastic,Aluminum



06001C-2HP19
 NW:21kgs
 GW:23.2kgs
 MEAS/CTN:70x64x31.5(cm)

材质:
 PA 塑料, 西皮, 高密度海绵, 铝合金脚
Material:
 PA nylon,high elastic mesh,sponge,fabric,
 plastic,Aluminum

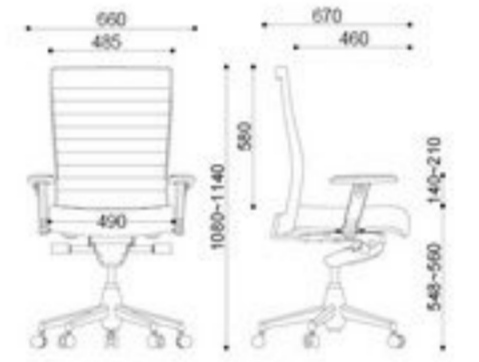

06001C-2P19-C
 NW:21kgs
 GW:23.2kgs
 MEAS/CTN:70x64x31.5(cm)

材质:
 PA 塑料, 网布, 定型海绵, 铝合金脚
Material:
 PA nylon,high elastic mesh,sponge,fabric,
 plastic,Aluminum

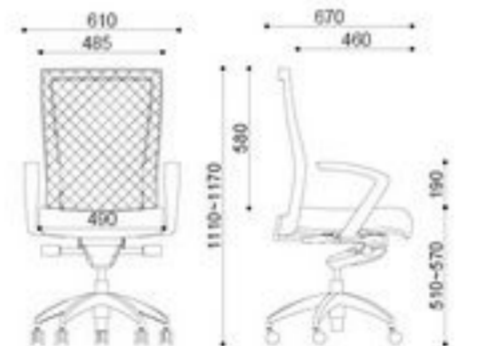

06001C-2P19-T
 NW:21kgs
 GW:23.2kgs
 MEAS/CTN:70x64x31.5(cm)

材质:
 PA 塑料, 网布, 定型海绵, 铝合金脚
Material:
 PA nylon,high elastic mesh,sponge,fabric,
 plastic,Aluminum

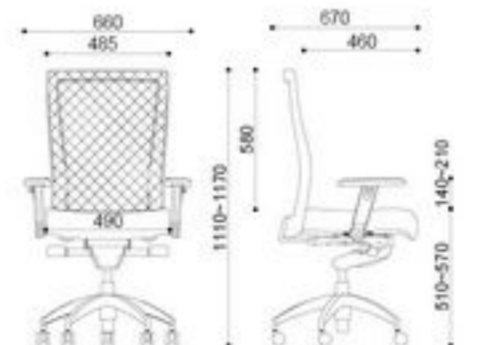

06001E-19-C
 NW:16.8kgs
 GW:18.8kgs
 MEAS/CTN:69x55x39(cm)

材质:
 PA 塑料, A3 钢架, 网布, 定型海绵
Material:
 PA nylon,high elastic mesh,sponge,fabric,
 plastic,Aluminum,A3 steel

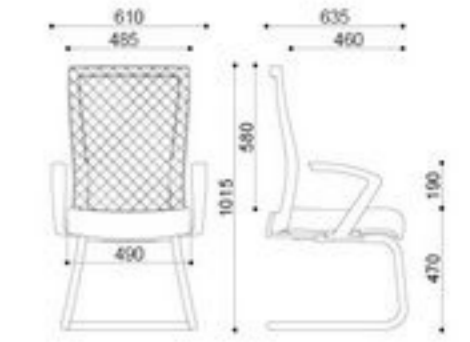

06002B-2WP5B
 NW:23kgs
 GW:25.2kgs
 MEAS/CTN:83x70x34(cm)

材质:
 PA 塑料, 进口高弹力网布, 铝合金脚
Material:
 PA nylon,high elastic mesh,plastic,Aluminum

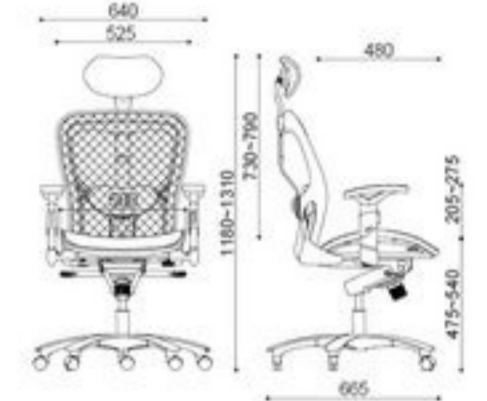

06002B-2WP5C
 NW:23kgs
 GW:25.2kgs
 MEAS/CTN:76x70x31.5(cm)

材质:
 PA 塑料, 进口高弹力网布, 铝合金脚
Material:
 PA nylon,high elastic mesh,plastic,Aluminum

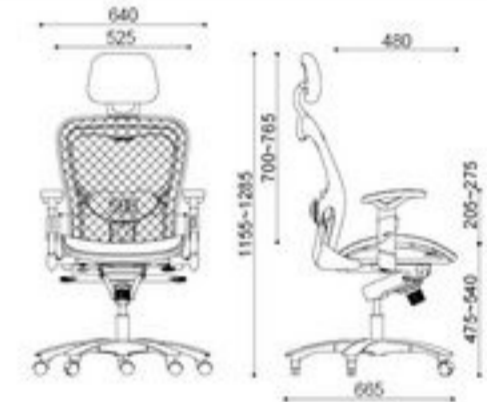

06002C-2WP5
 NW:22kgs
 GW:24.2kgs
 MEAS/CTN:76x70x31.5(cm)

材质:
 PA 塑料, 进口高弹力网布, 铝合金脚
Material:
 PA nylon,high elastic mesh,plastic,Aluminum

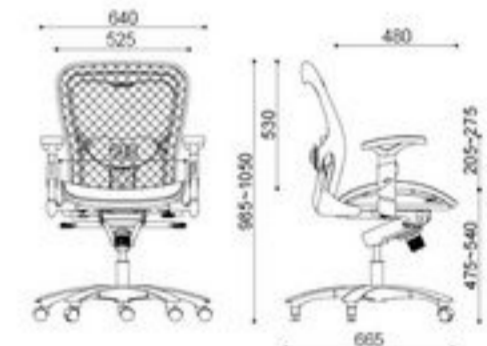

06002E-20W
 NW:17.8kgs
 GW:19.8kgs
 MEAS/CTN:69x55x39(cm)

材质:
 PA 塑料, A3 钢架, 进口高弹力网布
Material:
 PA nylon,high elastic mesh,plastic,Aluminum,
 A3 steel

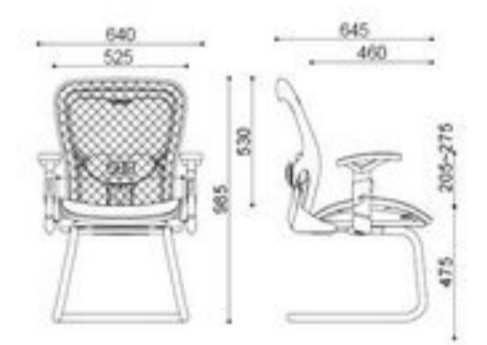



06002B-2P5B
 NW:23.2kgs
 GW:25.4kgs
 MEAS/CTN:83x70x34(cm)

材质:
 PA 塑料, 进口高弹力网布, 西皮, 定型海绵, 铝合金脚
Material:
 PA nylon,high elastic mesh,molded foam, faux leather,plastic,Aluminum

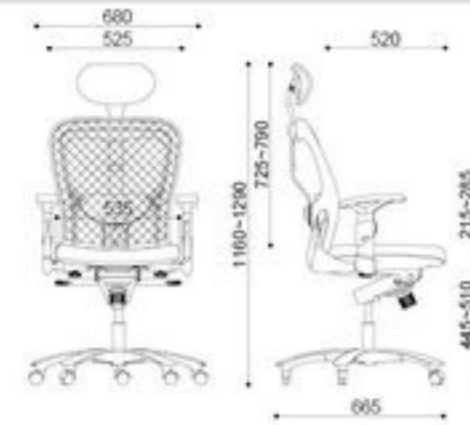

06002B-2P5C
 NW:23.2kgs
 GW:25.4kgs
 MEAS/CTN:76x70x31.5(cm)

材质:
 PA 塑料, 进口高弹力网布, 西皮, 定型海绵, 铝合金脚
Material:
 PA nylon,high elastic mesh,molded foam, faux leather,plastic,Aluminum

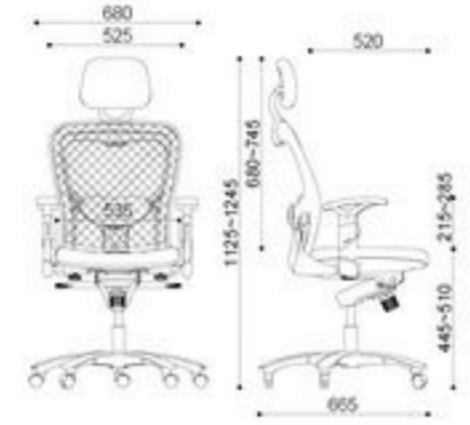

06002C-2P5
 NW:22kgs
 GW:24.2kgs
 MEAS/CTN:76x70x31.5(cm)

材质:
 PA 塑料, 进口高弹力网布, 西皮, 定型海绵, 铝合金脚
Material:
 PA nylon,high elastic mesh,molded foam, faux leather,plastic,Aluminum

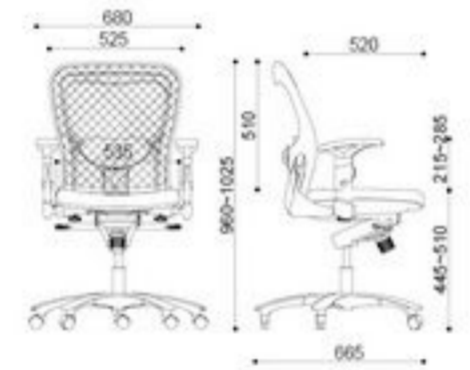

06002E-19
 NW:17.1kgs
 GW:19.1kgs
 MEAS/CTN:69x55x39(cm)

材质:
 PA 塑料, A3 钢架, 进口高弹力网布, 西皮, 定型海绵
Material:
 PA nylon,high elastic mesh,molded foam, faux leather,plastic,Aluminum,A3 steel

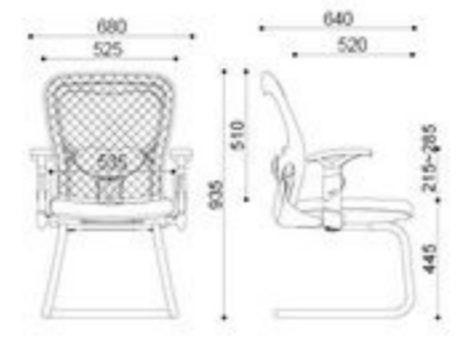

06002B-2HP5B
 NW:23.9kgs
 GW:26.1kgs
 MEAS/CTN:83x70x34(cm)

材质:
 PA 塑料, 西皮, 定型海绵, 尼龙脚
Material:
 PA nylon,high elastic mesh,molded foam,faux leather,plastic



06002B-2HP5C
 NW:23.9kgs
 GW:26.1kgs
 MEAS/CTN:76x70x31.5(cm)

材质:
 PA 塑料, 西皮, 定型海绵, 尼龙脚
Material:
 PA nylon,high elastic mesh,molded foam,faux leather,plastic

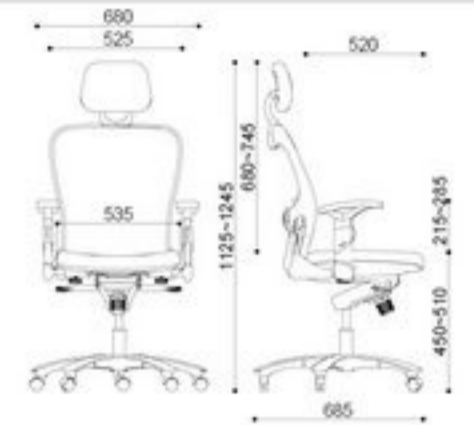

06002C-2HP5
 NW:21.5kgs
 GW:23.7kgs
 MEAS/CTN:76x70x31.5(cm)

材质:
 PA 塑料, 西皮, 定型海绵, 尼龙脚
Material:
 PA nylon,high elastic mesh,molded foam,faux leather,plastic

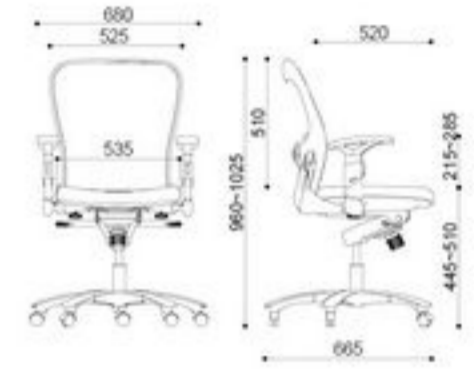

06002E-19H
 NW:18.8kgs
 GW:20.8kgs
 MEAS/CTN:69x55x39(cm)

材质:
 PA 塑料, A3 钢架, 西皮, 定型海绵
Material:
 PA nylon,high elastic mesh,molded foam, faux leather,plastic,A3 steel

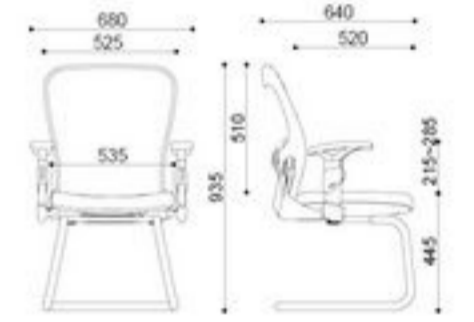

0634B-2P5B
 NW:24.8kgs
 GW:27kgs
 MEAS/CTN:83x70x34(cm)

材质:
 PA 塑料, 进口高弹力网布, 定型海绵, 铝合金脚
Material:
 PA nylon,high elastic mesh,molded foam,fabric, plastic,Aluminum



0634B-2P5C
 NW:24.8kgs
 GW:27kgs
 MEAS/CTN:76x70x31.5(cm)

材质:
 PA 塑料, 进口高弹力网布, 定型海绵, 铝合金脚
Material:
 PA nylon,high elastic mesh,molded foam,fabric, plastic,Aluminum





0634C-2P5
 NW:23kgs
 GW:25.2kgs
 MEAS/CTN:76x70x31.5(cm)

材质:
 PA 塑料, 进口高弹力网布, 定型海绵, 铝合金脚
Material:
 PA nylon,high elastic mesh,molded foam,fabric,
 plastic,Aluminum

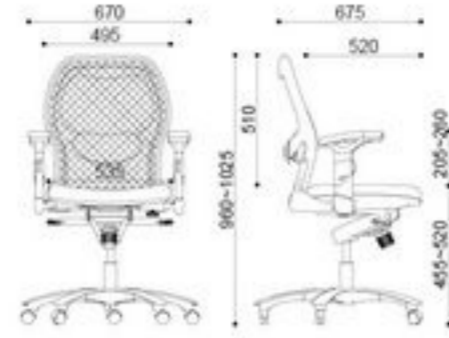

0634E-16
 NW:19.5kgs
 GW:21.5kgs
 MEAS/CTN:69x55x39(cm)

材质:
 PA 塑料, A3 钢架, 进口高弹力网布, 定型海绵
Material:
 PA nylon,high elastic mesh,molded foam,fabric,
 plastic,Aluminum,A3 steel

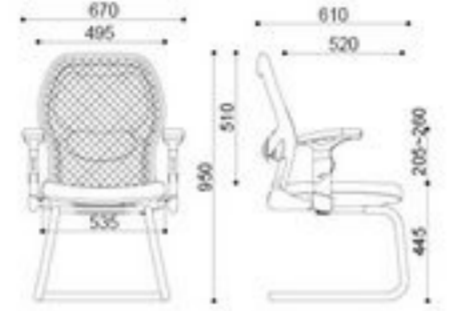

0634B-2WP5B
 NW:24.8kgs
 GW:27kgs
 MEAS/CTN:83x70x34(cm)

材质:
 PA 塑料, 进口高弹力网布, 铝合金脚
Material:
 PA nylon,high elastic mesh,plastic,Aluminum

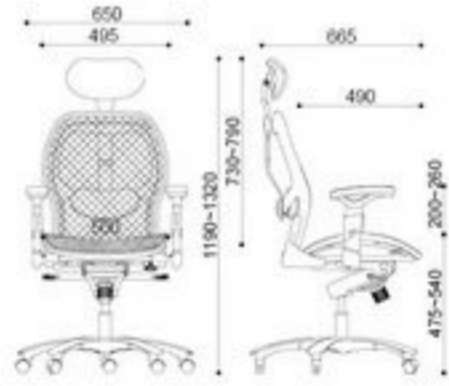

0634B-2WP5C
 NW:24.8kgs
 GW:27kgs
 MEAS/CTN:76x70x31.5(cm)

材质:
 PA 塑料, 进口高弹力网布, 铝合金脚
Material:
 PA nylon,high elastic mesh,plastic,Aluminum



0634C-2WP5
 NW:23kgs
 GW:25.2kgs
 MEAS/CTN:76x70x31.5(cm)

材质:
 PA 塑料, 进口高弹力网布, 铝合金脚
Material:
 PA nylon,high elastic mesh,plastic,Aluminum

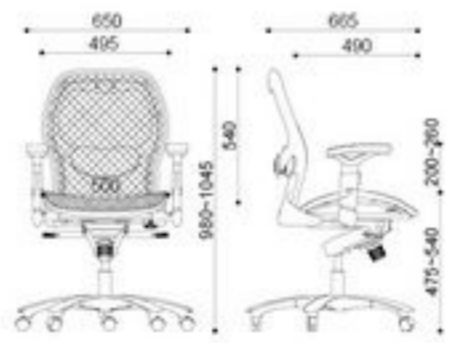

0634E-18W
 NW:19.2kgs
 GW:21.2kgs
 MEAS/CTN:70x55x37(cm)

材质:
 PA 塑料, A3 钢架, 进口高弹力网布
Material:
 PA nylon,high elastic mesh,plastic,Aluminum,
 A3 steel

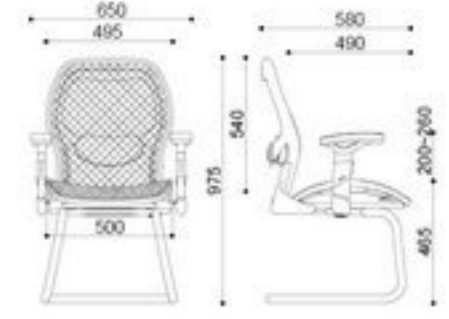

06004B-2P5C
 NW:22.4kgs
 GW:24.6kgs
 MEAS/CTN:76x70x31.5(cm)

材质:
 PA 塑料, 进口高弹力网布, 西皮, 定型海绵,
 尼龙脚
Material:
 PA nylon,high elastic mesh,molded foam,
 faux leather,plastic



06004C-2P5
 NW:21.4kgs
 GW:23.6kgs
 MEAS/CTN:76x70x31.5(cm)

材质:
 PA 塑料, 进口高弹力网布, 西皮, 定型海绵,
 尼龙脚
Material:
 PA nylon,high elastic mesh,molded foam,
 faux leather,plastic

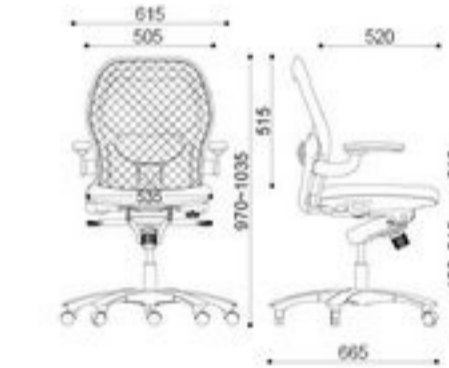

06004E-19
 NW:17kgs
 GW:19kgs
 MEAS/CTN:69x55x39(cm)

材质:
 PA 塑料, A3 钢架, 进口高弹力网布, 西皮,
 定型海绵
Material:
 PA nylon,high elastic mesh,molded foam,
 faux leather,plastic,A3 steel

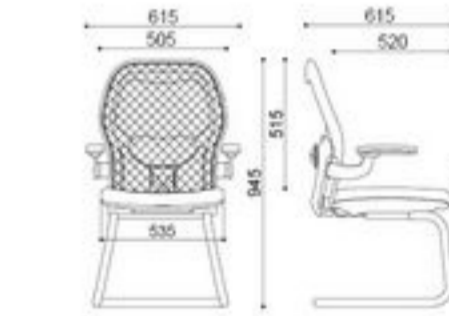

06004C-2WP5
 NW:21.4kgs
 GW:23.6kgs
 MEAS/CTN:76x70x31.5(cm)

材质:
 PA 塑料, 进口高弹力网布, 尼龙脚
Material:
 PA nylon,high elastic mesh,molded foam,
 faux leather,plastic,Aluminum

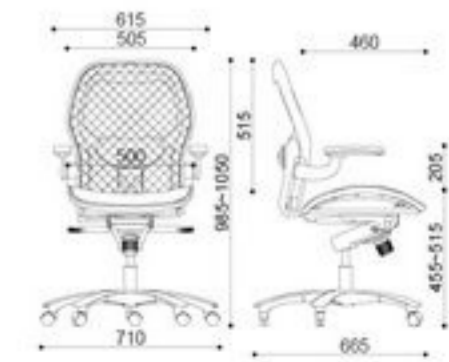



06004E-20W
 NW:16.8kgs
 GW:18.8kgs
 MEAS/CTN:69x55x39(cm)

材质:
 PA 塑料, A3 钢架, 进口高弹力网布
Material:
 PA nylon,high elastic mesh,molded foam,
 faux leather,plastic,Aluminum,A3 steel

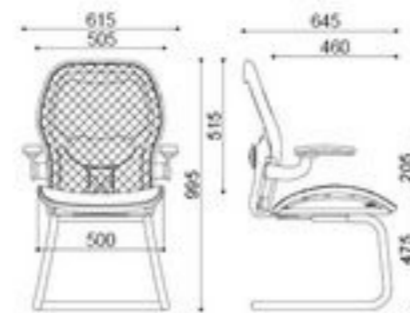

1302F-1
 NW:9.3kgs
 GW:11.1kgs
 MEAS/CTN:65x60x36(cm)

材质:
 PA 塑料, A3 钢, 尼龙脚
Material:
 PA nylon, A3 steel

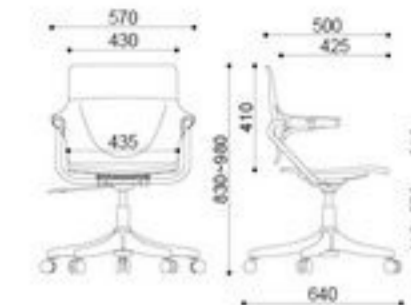

06004C-2HP5
 NW:21.5kgs
 GW:23.7kgs
 MEAS/CTN:76x70x31.5(cm)

材质:
 PA 塑料, 西皮, 定型海绵, 尼龙脚
Material:
 PA nylon,high elastic mesh,molded foam,
 faux leather,plastic



1302E-34
 NW:18.6kgs/2pcs
 GW:20.6kgs/2pcs
 MEAS/CTN:88x55x59(cm)
 PACKING:2pcs/CTN

材质:
 PA 塑料, A3 钢
Material:
 PA nylon, A3 steel

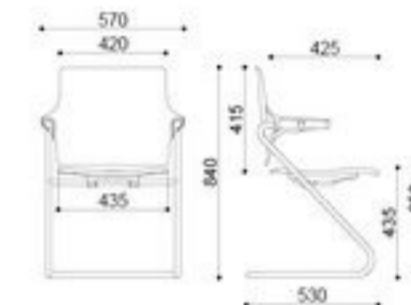

06004E-19H
 NW:17kgs
 GW:19kgs
 MEAS/CTN:69x55x39(cm)

材质:
 PA 塑料, A3 钢架, 西皮, 定型海绵
Material:
 PA nylon,high elastic mesh,molded foam,
 faux leather,plastic,A3 steel

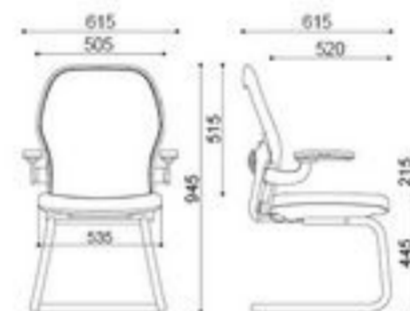

1001C-2
 NW:10kgs
 GW:11.8kgs
 MEAS/CTN:62x60x38(cm)

材质:
 PA 塑料, 网布, 定型海绵, 尼龙脚
Material:
 PA nylon,elastic mesh,fabric,molded foam,plastic

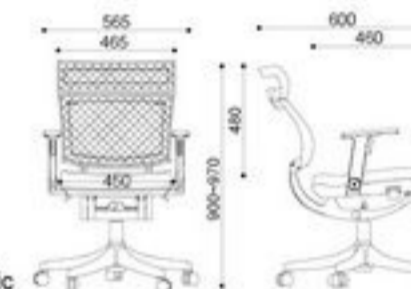

06004C-2P13
 NW:20.4kgs
 GW:22.6kgs
 MEAS/CTN:76x70x31.5(cm)

材质:
 PA 塑料, 网布, 高密度海绵, 尼龙脚
Material:
 PA nylon,high elastic mesh,molded foam,
 faux leather,plastic

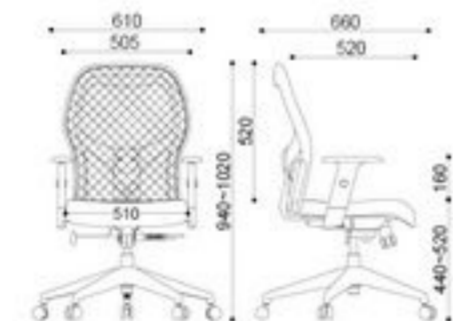

1001F-2
 NW:9.5kgs
 GW:11.3kgs
 MEAS/CTN:62x60x34(cm)

材质:
 PA 塑料, 网布, 定型海绵, 尼龙脚
Material:
 PA nylon,elastic mesh,fabric,molded foam,plastic

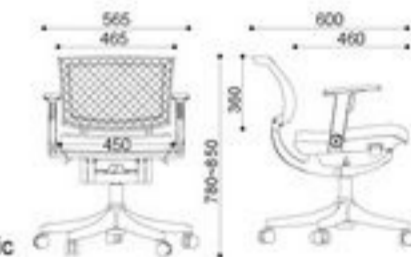

06004E-19-B
 NW:16kgs
 GW:18kgs
 MEAS/CTN:69x55x39(cm)

材质:
 PA 塑料, A3 钢架, 网布, 高密度海绵
Material:
 PA nylon,high elastic mesh,molded foam,
 faux leather,plastic,A3 steel

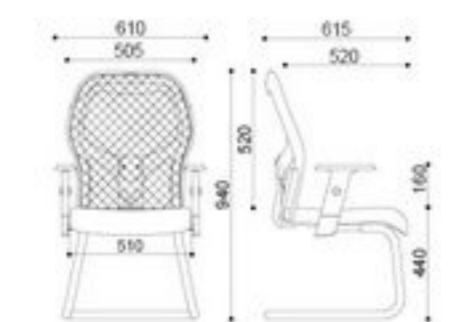

0902F-2P13
 NW:13.5kgs
 GW:15.5kgs
 MEAS/CTN:61x57x33(cm)

材质:
 PA 塑料, 网布, 定型海绵, 尼龙脚
Material:
 PA nylon,elastic mesh,sponge,fabric,
 plastic,Aluminum

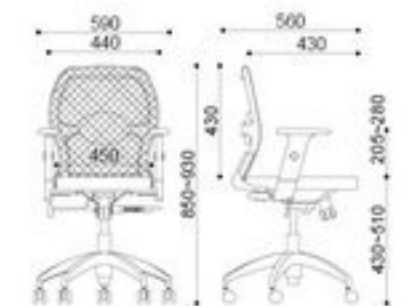



0902FE-29
 NW:11kgs
 GW:13kgs
 MEAS/CTN:55x50x39(cm)

材质:
 PA 塑料, A3 钢架, 网布, 定型海绵
Material:
 PA nylon,elastic mesh,molded foam,fabric,plastic,
 Aluminum,A3 steel



0801H-26S
 NW:10.3kgs
 GW:12.5kgs
 MEAS/CTN:85x31.5x60.5(cm)

材质:
 PP 塑料, A3 钢架, 网布, 定型海绵
Material:
 PP,molded foam, mesh,fabric,A3 steel

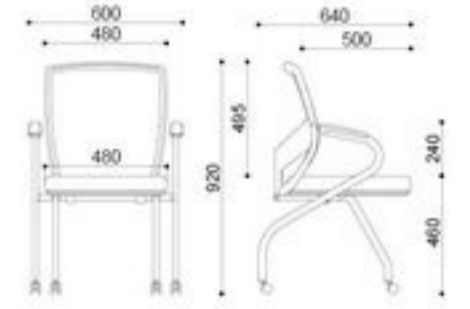

0801F-2P13M
 NW:15.6kgs
 GW:17.8kgs
 MEAS/CTN:68x64x38(cm)

材质:
 PP 塑料, 网布, 定型海绵, 黑色铝合金脚
Material:
 PP,molded foam, mesh,fabric,Aluminum

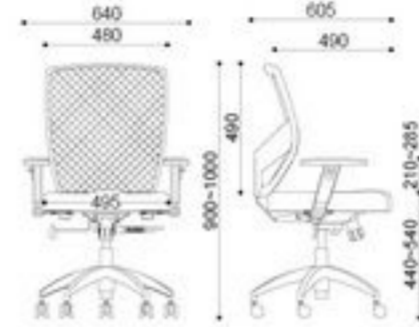

0801H-27
 NW:10.8kgs
 GW:13kgs
 MEAS/CTN:85x31.5x60.5(cm)

材质:
 PP 塑料, A3 钢架, 网布,
 定型海绵
Material:
 PP,molded foam, mesh,
 fabric,A3 steel



0801F-2P13
 NW:14.1kgs
 GW:16.3kgs
 MEAS/CTN:68x64x38(cm)

材质:
 PP 塑料, 网布, 定型海绵, 铝合金脚
Material:
 PP,molded foam, mesh,fabric,Aluminum

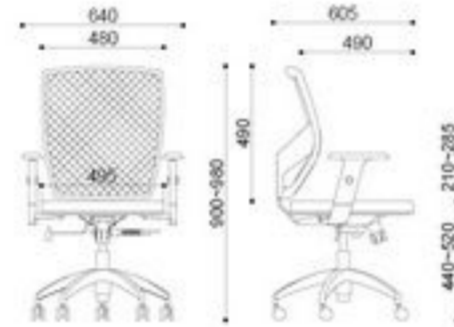

0801H-27S
 NW:10.9kgs
 GW:13.1kgs
 MEAS/CTN:85x31.5x60.5(cm)

材质:
 PP 塑料, A3 钢架, 网布,
 定型海绵
Material:
 PP,molded foam, mesh,
 fabric,A3 steel

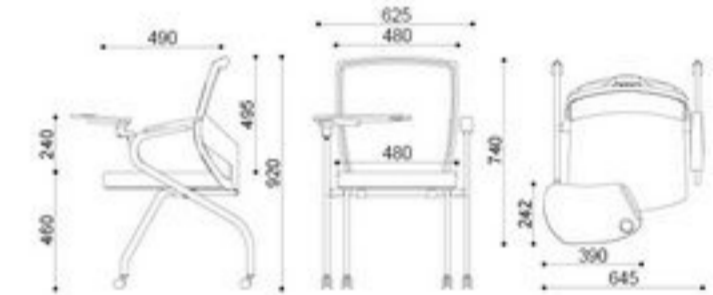

0801E-25
 NW:11.8kgs
 GW:13.8kgs
 MEAS/CTN:58x39x50(cm)

材质:
 PP 塑料, A3 钢架, 网布, 定型海绵
Material:
 PP,molded foam, mesh,fabric,A3 steel

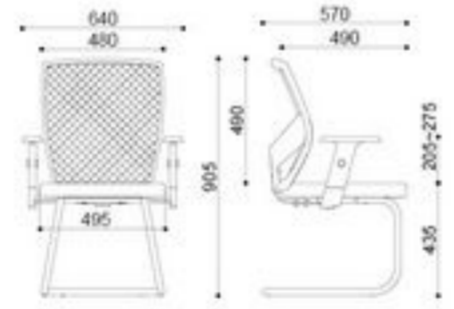

07001F-1P8
 NW:10.3kgs
 GW:12.3kgs
 MEAS/CTN:69x33x55(cm)

材质:
 PA 塑料, 网布, 高密度海绵, 尼龙脚
Material:
 PA nylon,sponge,mesh, fabric,plastic

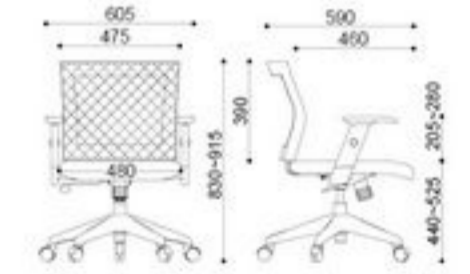

0801H-26
 NW:10kgs
 GW:12.2kgs
 MEAS/CTN:85x31.5x60.5(cm)

材质:
 PP 塑料, A3 钢架, 网布, 定型海绵
Material:
 PP,molded foam, mesh,fabric,A3 steel

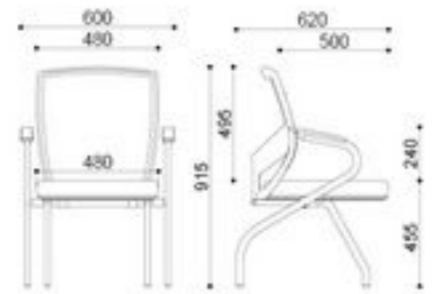

07001FE-23
 NW:22kgs/2pcs
 GW:25.8kgs/2pcs
 MEAS/CTN:
 Back & Seat: 68x39x51(cm)
 Base: 51x51x30(cm)
 PACKING:2pcs/CTN

材质:
 PA 塑料, A3 钢架, 网布, 高密度海绵
Material:
 PA nylon,sponge,mesh, fabric,plastic,A3 steel

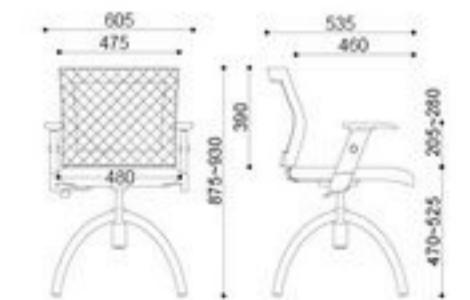



07001FE-17
 NW:9.5kgs
 GW:11.5kgs
 MEAS/CTN:69x55x39(cm)

材质:
 PA 塑料, A3 钢架, 网布, 高密度海绵
Material:
 PA nylon, sponge, mesh, fabric, plastic, A3 steel

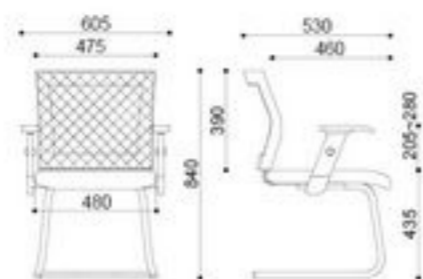

06001FE-22
 NW:15.2kgs/2pcs
 GW:17.2kgs/2pcs
 MEAS/CTN:57x53x43(cm)
 PACKING:2pcs/CTN

材质:
 PA 塑料, A3 钢架, 网布, 高密度海绵
Material:
 PA nylon, sponge, mesh, fabric, A3 steel

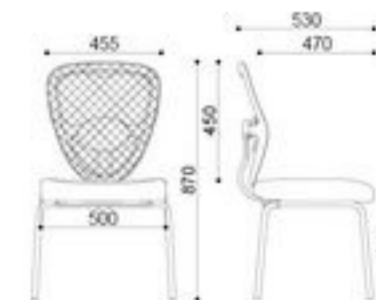

07001FE-21
 NW:14.6kgs/2pcs
 GW:16.6kgs/2pcs
 MEAS/CTN:61x59x50(cm)
 PACKING:2pcs/CTN

材质:
 PA 塑料, A3 钢架, 网布, 高密度海绵
Material:
 PA nylon, sponge, mesh, fabric, plastic, A3 steel

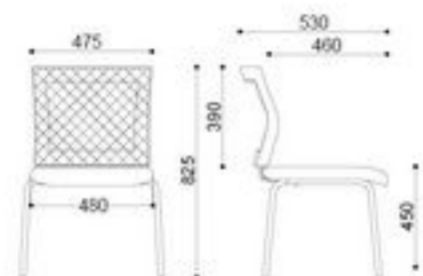

1203E-33
 NW:16.4kgs/2pcs
 GW:18.2kgs/2pcs
 MEAS/CTN:56x55x58(cm)
 PACKING:2pcs/CTN

材质:
 PA 塑料, A3 钢架, 网布, 定型海绵
Material:
 PA nylon, plastic, elastic mesh, fabric, A3 steel

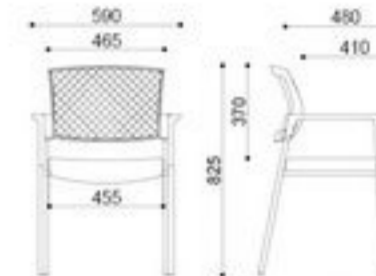

06001F-2P6
 NW:11.8kgs
 GW:13.8kgs
 MEAS/CTN:61x57x33(cm)

材质:
 PA 塑料, 网布, 高密度海绵, 尼龙脚
Material:
 PA nylon, sponge, mesh, fabric, plastic

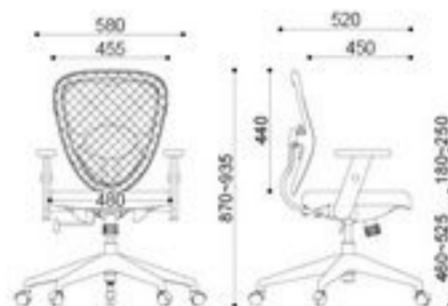

1203E-33S
 NW:17kgs/2pcs
 GW:18.8kgs/2pcs
 MEAS/CTN:56x55x58(cm)
 PACKING:2pcs/CTN

材质:
 PA 塑料, A3 钢架, 网布, 定型海绵
Material:
 PA nylon, plastic, elastic mesh, fabric, A3 steel

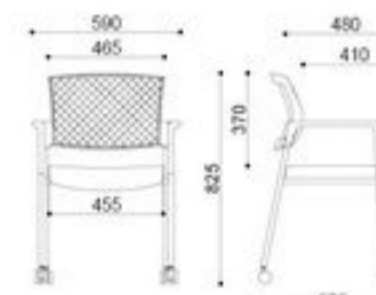

06001FE-24
 NW:21.6kgs/2pcs
 GW:25.4 kgs/2pcs
 MEAS/CTN:
 Back & Seat: 68x39x51(cm)
 Base: 51x51x30(cm)
 PACKING:2pcs/CTN

材质:
 PA 塑料, A3 钢架, 网布, 高密度海绵
Material:
 PA nylon, sponge, mesh, fabric, A3 steel

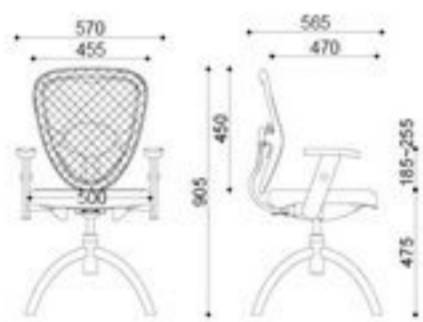

1203E-33-1
 NW:19.8kgs/2pcs
 GW:21.6kgs/2pcs
 MEAS/CTN:56x55x58(cm)
 PACKING:2pcs/CTN

材质:
 PA 塑料, A3 钢架, 网布, 定型海绵
Material:
 PA nylon, plastic, elastic mesh, fabric, A3 steel

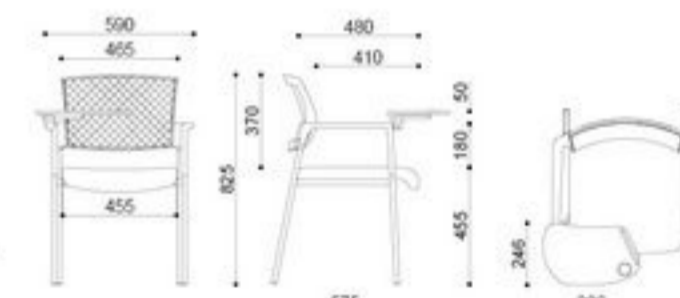

06001FE-15
 NW:10kgs
 GW:12kgs
 MEAS/CTN:58x39x50(cm)

材质:
 PA 塑料, A3 钢架, 网布, 高密度海绵
Material:
 PA nylon, sponge, mesh, fabric, A3 steel

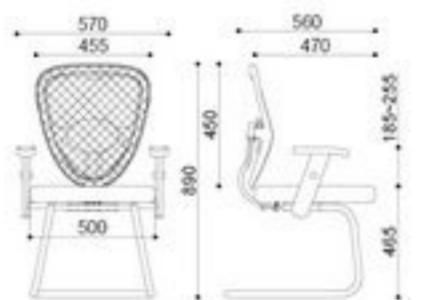

1203E-33S-1
 NW:20kgs/2pcs
 GW:21.8kgs/2pcs
 MEAS/CTN:56x55x58(cm)
 PACKING:2pcs/CTN

材质:
 PA 塑料, A3 钢架, 网布, 定型海绵
Material:
 PA nylon, plastic, elastic mesh, fabric, A3 steel

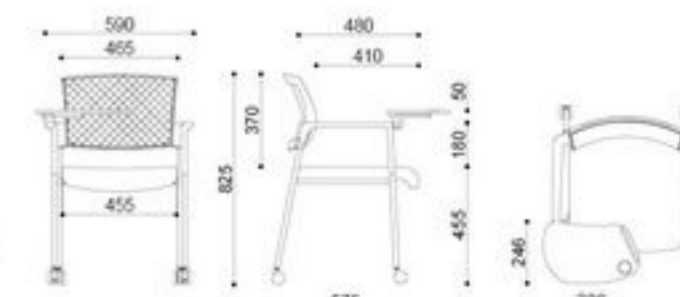



1002E-31
 NW:6.5kgs
 GW:8.3kgs
 MEAS/CTN:81x57x14(cm)

材质:
 PA 塑料, A3 钢架, 网布, 定型海棉
Material:
 PA nylon,elastic mesh,fabric,molded foam,
 plastic,A3 steel

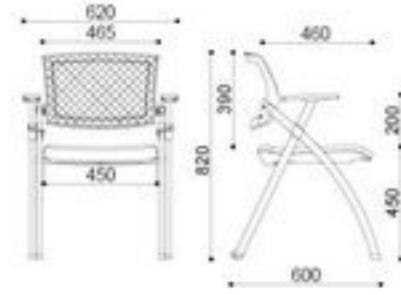

1002E-31FS-1
 NW:7.6kgs
 GW:9.4kgs
 MEAS/CTN:81x57x14(cm)

材质:
 PA 塑料, A3 钢架, 网布,
 定型海棉
Material:
 PA nylon,elastic mesh,fabric,
 molded foam,plastic,A3 steel

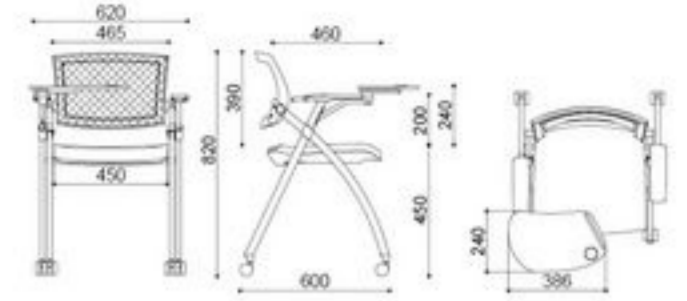

1002E-31F
 NW:6.5kgs
 GW:8.3kgs
 MEAS/CTN:81x57x14(cm)

材质:
 PA 塑料, A3 钢架, 网布, 定型海棉
Material:
 PA nylon,elastic mesh,fabric,molded foam,
 plastic,A3 steel

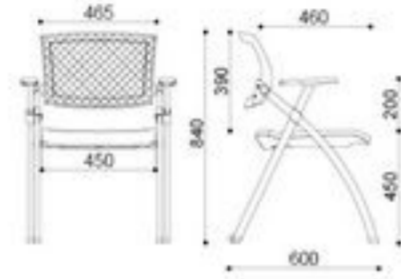

1003E-32
 NW:8kgs/2pcs
 GW:9.8kgs/2pcs
 MEAS/CTN:71x52.5x27(cm)
 PACKING:2pcs/CTN

材质:
 PA 塑料, A3 钢架
Material:
 PA nylon, A3 steel

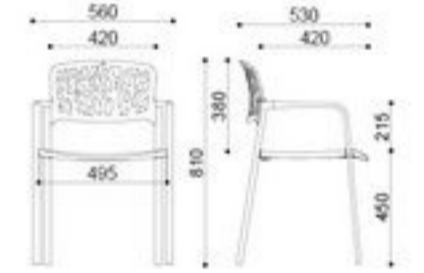

1002E-31S
 NW:6.7kgs
 GW:8.5kgs
 MEAS/CTN:81x57x14(cm)

材质:
 PA 塑料, A3 钢架, 网布, 定型海棉
Material:
 PA nylon,elastic mesh,fabric,molded
 foam,plastic,A3 steel,Aluminum

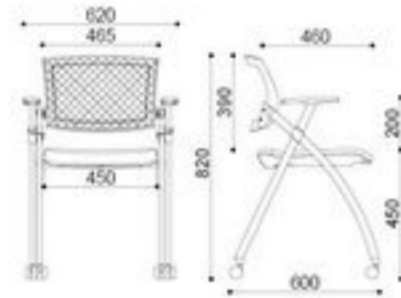

06002F-3
 NW:36kgs/4pcs
 GW:40kgs/4pcs
 MEAS/CTN:109x73x73.5(cm)
 PACKING:4pcs/CTN

材质:
 PP 塑料, A3 钢架
Material:
 PP, A3 steel

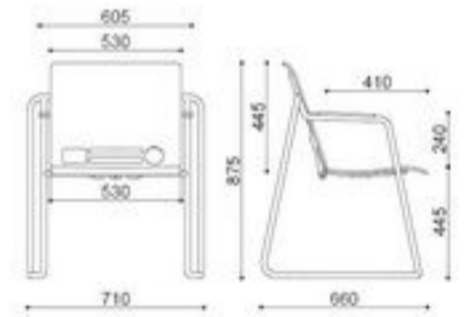

1002E-31-1
 NW:7.4kgs
 GW:9.2kgs
 MEAS/CTN:81x57x14(cm)

材质:
 PA 塑料, A3 钢架, 网布,
 定型海棉
Material:
 PA nylon,elastic mesh,fabric,molded
 foam,plastic,A3 steel,Aluminum

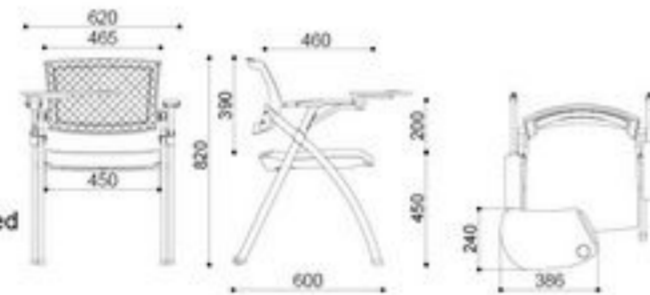

E-9
 NW:23.2kgs/4pcs
 GW:26.2kgs/4pcs
 MEAS/CTN:105x70x57(cm)
 PACKING:4pcs/CTN

材质:
 PP 塑料, A3 钢架, 海绵, 网布
Material:
 PP,sponge,mesh,fabric,A3 steel

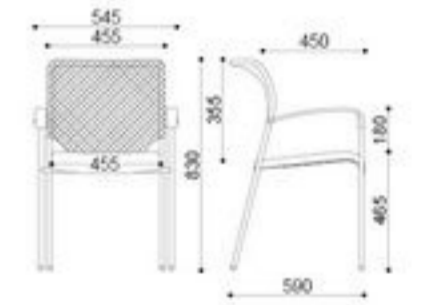

1002E-31S-1
 NW:7.6kgs
 GW:9.4kgs
 MEAS/CTN:81x57x14(cm)

材质:
 PA 塑料, A3 钢架, 网布,
 定型海棉
Material:
 PA nylon,elastic mesh,fabric,molded
 foam,plastic,A3 steel,Aluminum

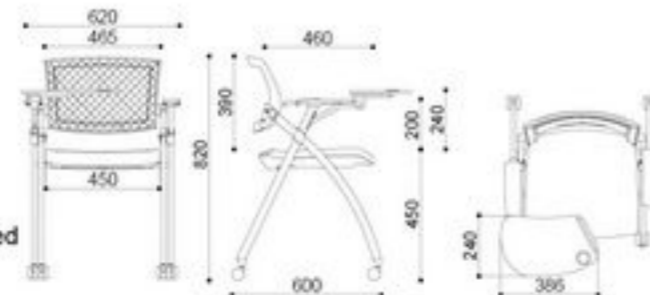

E-9-1
 NW:26.6kgs/4pcs
 GW:29.6kgs/4pcs
 MEAS/CTN:105x70x57(cm)
 PACKING:4pcs/CTN

材质:
 PP 塑料, A3 钢架, 海绵, 网布
Material:
 PP,sponge,mesh,fabric,A3 steel

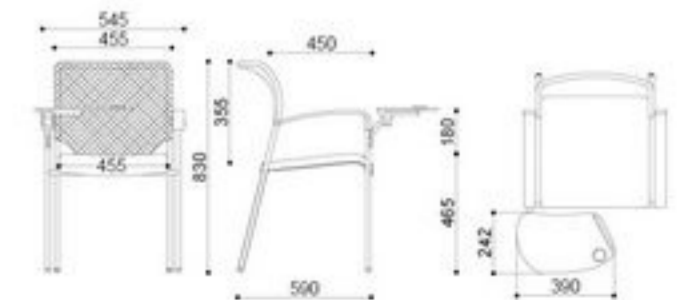

**E-9H**

NW:23.2kgs/4pcs
 GW:26.2kgs/4pcs
 MEAS/CTN:105x70x57(cm)
 PACKING:4pcs/CTN

材质:
 PP 塑料, A3 钢架, 海绵, 西皮
Material:
 PP,sponge,mesh,fabric,A3 steel

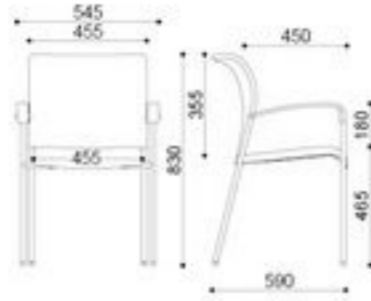
**E-9H-1**

NW:26.6kgs/4pcs
 GW:29.6kgs/4pcs
 MEAS/CTN:105x70x57(cm)
 PACKING:4pcs/CTN

材质:
 PP 塑料, A3 钢架, 海绵, 西皮
Material:
 PP,sponge,mesh,fabric,A3 steel

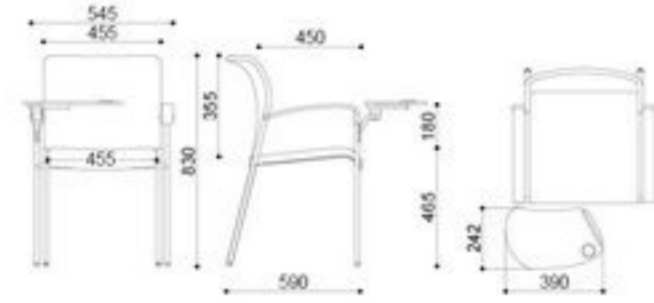
**E-9S**

NW:17.6kgs/4pcs
 GW:20.6kgs/4pcs
 MEAS/CTN:105x70x57(cm)
 PACKING:4pcs/CTN

材质:
 PP 塑料, A3 钢架
Material:
 PP,sponge,mesh,fabric,A3 steel

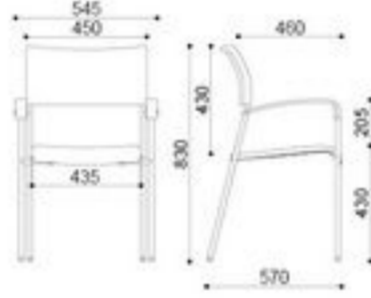
**E-9S-1**

NW:21kgs/4pcs
 GW:24kgs/4pcs
 MEAS/CTN:105x70x57(cm)
 PACKING:4pcs/CTN

材质:
 PP 塑料, A3 钢架
Material:
 PP,plastic,sponge,mesh,
 fabric,A3 steel

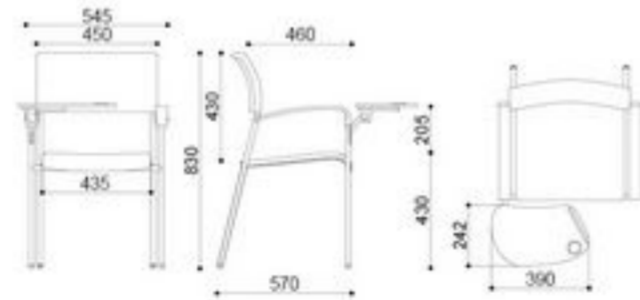
**E-10**

NW:17.2kgs/2pcs
 GW:19.4kgs/2pcs
 MEAS/CTN:72x59x53(cm)
 PACKING:2pcs/CTN

材质:
 A3 钢架, 海绵, 网布
Material:
 Sponge,mesh,fabric,A3 steel

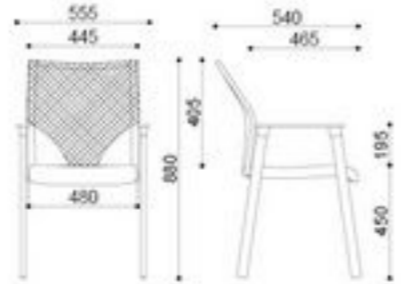
**17B-1**

NW:18.7kgs
 GW:21.2kgs
 MEAS/CTN:85x48x52(cm)

材质:
 A3 钢, 台网, 铝合金扶手, 铝合金脚
Material:
 A3 steel, elastic mesh,Aluminum

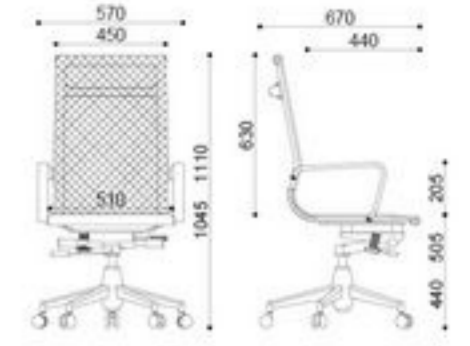
**17C-1**

NW:18.5kgs
 GW:21kgs
 MEAS/CTN:80x45x52(cm)

材质:
 A3 钢, 台网, 铝合金扶手, 铝合金脚
Material:
 A3 steel, elastic mesh,Aluminum

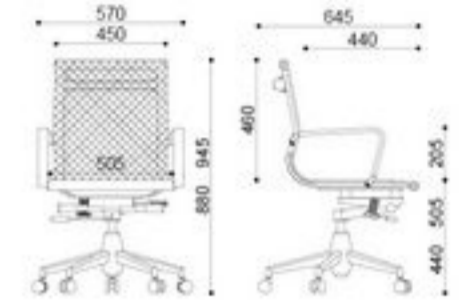
**17D-1**

NW:9.5kgs
 GW:12kgs
 MEAS/CTN:75x48x52(cm)

材质:
 A3 钢, 台网, 铝合金扶手, 铝合金脚
Material:
 A3 steel, elastic mesh,Aluminum

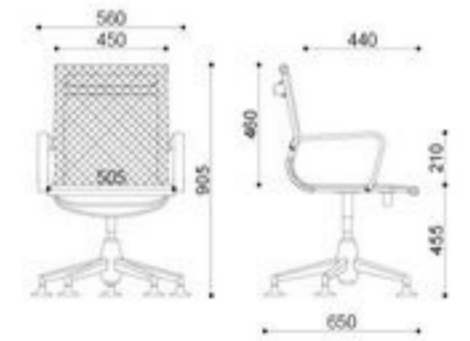
**17E-5**

NW:12.5kgs
 GW:15kgs
 MEAS/CTN:75x42x52(cm)

材质:
 A3 钢, 台网, 铝合金扶手
Material:
 A3 steel, elastic mesh,Aluminum

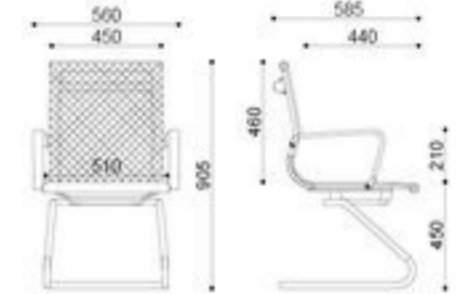
**17B-1H**

NW:19kgs
 GW:21.5kgs
 MEAS/CTN:85x48x52(cm)

材质:
 A3 钢, 西皮, 铝合金扶手, 铝合金脚
Material:
 A3 steel, faux leather, mesh,Aluminum

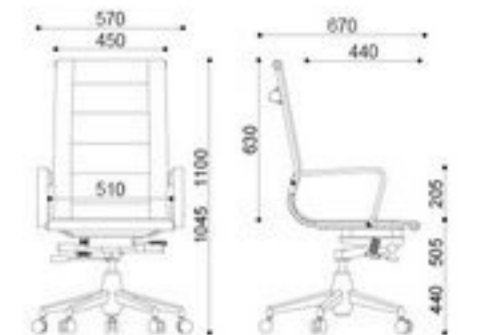



17C-1H
 NW:18.5kgs
 GW:21kgs
 MEAS/CTN:80x45x52(cm)

材质:
 A3 钢, 西皮, 铝合金扶手, 铝合金脚
Material:
 A3 steel, faux leather, mesh, Aluminum

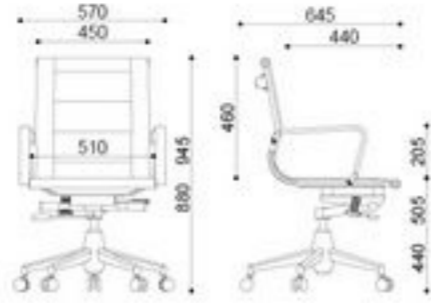

0517D-1
 NW:11.2kgs
 GW:13.5kgs
 MEAS/CTN:75x48x52(cm)

材质:
 A3 钢, 进口高弹力网, 铝合金扶手, 铝合金脚
Material:
 A3 steel, elastic mesh, Aluminum

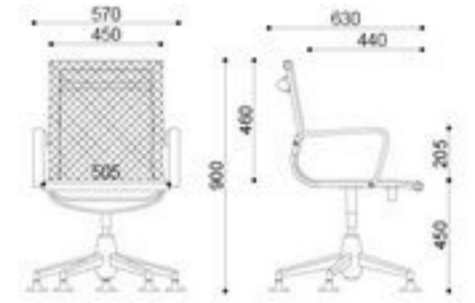

17D-1H
 NW:12.5kgs
 GW:15kgs
 MEAS/CTN:75x48x52(cm)

材质:
 A3 钢, 西皮, 铝合金扶手, 铝合金脚
Material:
 A3 steel, faux leather, mesh, Aluminum

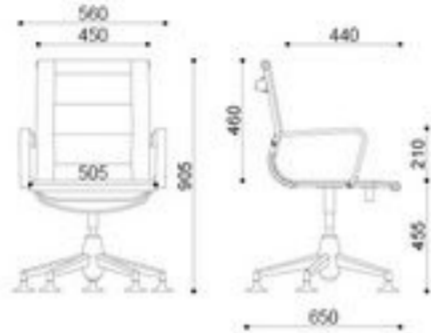

0517E-5
 NW:13.7kgs
 GW:15.7kgs
 MEAS/CTN:75x42x52(cm)

材质:
 A3 钢, 进口高弹力网, 铝合金扶手
Material:
 A3 steel, elastic mesh, Aluminum

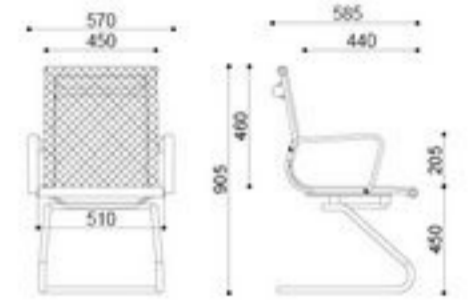

17E-5H
 NW:14.5kgs
 GW:17kgs
 MEAS/CTN:75x42x52(cm)

材质:
 A3 钢, 西皮, 铝合金扶手
Material:
 A3 steel, faux leather, mesh, Aluminum

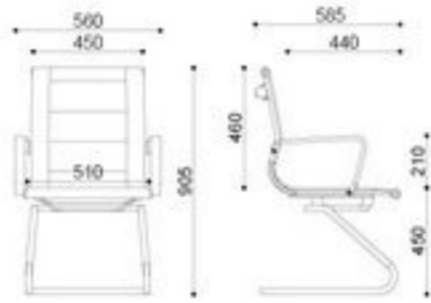

0517B-1HP5
 NW:17.4kgs
 GW:20kgs
 MEAS/CTN:85x48x52(cm)

材质:
 A3 钢, 西皮, 铝合金扶手, 铝合金脚
Material:
 A3 steel, faux leather, mesh, Aluminum

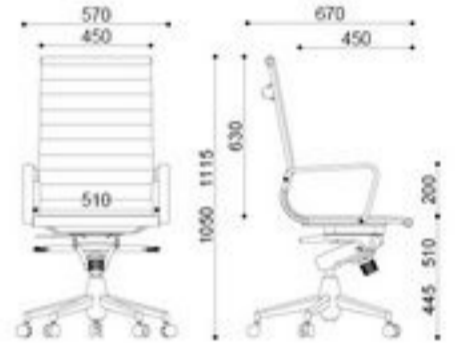

0517B-1P5
 NW:18.3kgs
 GW:20.5kgs
 MEAS/CTN:85x48x52(cm)

材质:
 A3 钢, 进口高弹力网, 铝合金扶手, 铝合金脚
Material:
 A3 steel, elastic mesh, Aluminum

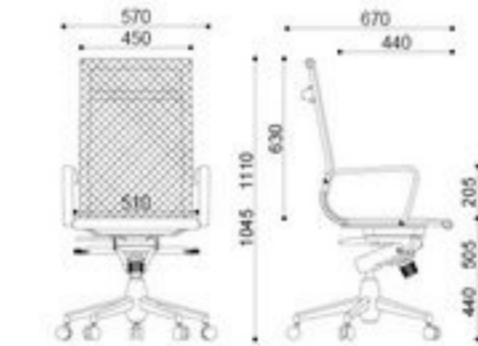

0517C-1HP5
 NW:16.4kgs
 GW:19kgs
 MEAS/CTN:80x45x52(cm)

材质:
 A3 钢, 西皮, 铝合金扶手, 铝合金脚
Material:
 A3 steel, faux leather, mesh, Aluminum



0517C-1P5
 NW:17.7kgs
 GW:19.5kgs
 MEAS/CTN:80x45x52(cm)

材质:
 A3 钢, 进口高弹力网, 铝合金扶手, 铝合金脚
Material:
 A3 steel, elastic mesh, Aluminum

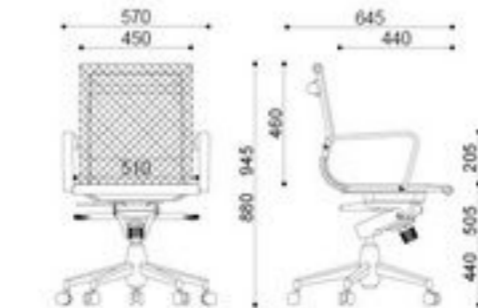

0517D-1H
 NW:11.2kgs
 GW:13.5kgs
 MEAS/CTN:75x48x52(cm)

材质:
 A3 钢, 西皮, 铝合金扶手, 铝合金脚
Material:
 A3 steel, faux leather, mesh, Aluminum

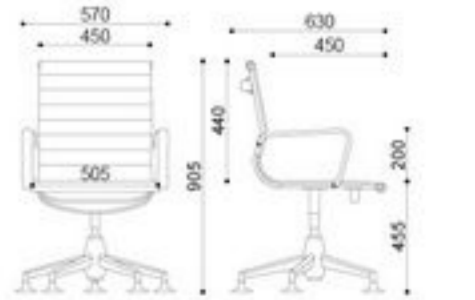



0517E-5H
 NW:13.7kgs
 GW:16.2kgs
 MEAS/CTN:75x42x52(cm)

材质:
 A3 钢, 西皮, 铝合金扶手
Material:
 A3 steel, faux leather, mesh, Aluminum

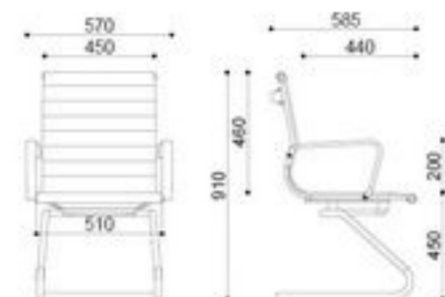

0517B-1PP4
 NW:12.4kgs
 GW:15.4kgs
 MEAS/CTN:85x50x52(cm)

材质:
 A3 钢, 西皮, 尼龙扶手, 尼龙脚
Material:
 PA nylon, plastic, A3 steel, faux leather, mesh

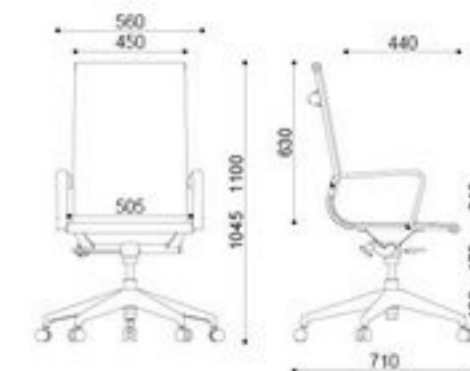

0517B-1TP4
 NW:12.5kgs
 GW:15kgs
 MEAS/CTN:85x50x52(cm)

材质:
 A3 钢, 台网, 尼龙扶手, 尼龙脚, 白色喷漆
Material:
 PA nylon, plastic, A3 steel, mesh

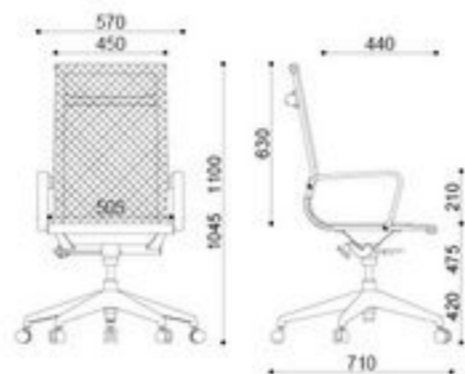

0517C-1PP4
 NW:11.8kgs
 GW:14.8kgs
 MEAS/CTN:75x45x52(cm)

材质:
 A3 钢, 西皮, 尼龙扶手, 尼龙脚
Material:
 PA nylon, plastic, A3 steel, faux leather, mesh

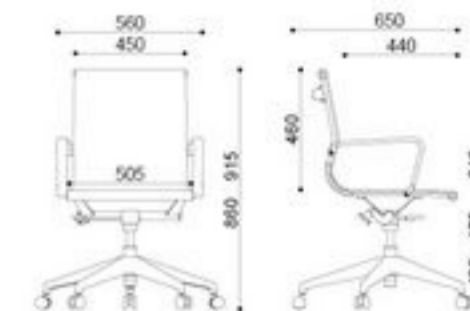

0517C-1TP4
 NW:11.7kgs
 GW:14.2kgs
 MEAS/CTN:75x45x52(cm)

材质:
 A3 钢, 台网, 尼龙扶手, 尼龙脚, 白色喷漆
Material:
 PA nylon, plastic, A3 steel, mesh

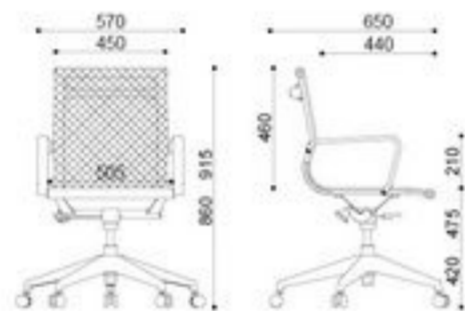

0517D-1P
 NW:9.8kgs
 GW:12.8kgs
 MEAS/CTN:75x48x52(cm)

材质:
 A3 钢, 西皮, 尼龙扶手, 尼龙脚
Material:
 PA nylon, plastic, A3 steel, faux leather, mesh

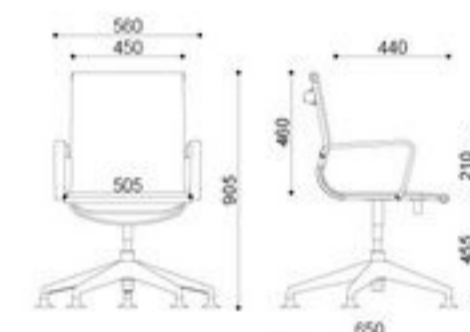

0517D-1T
 NW:9.5kgs
 GW:12kgs
 MEAS/CTN:75x48x52(cm)

材质:
 A3 钢, 台网, 尼龙扶手, 尼龙脚, 白色喷漆
Material:
 PA nylon, plastic, A3 steel, mesh

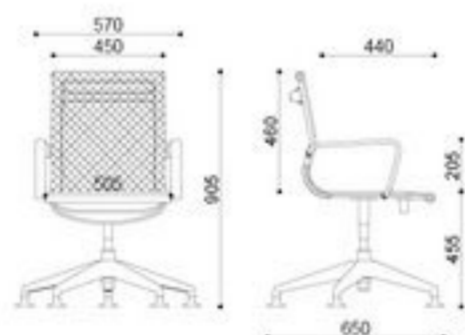

0517E-5P
 NW:12.5kgs
 GW:15.5kgs
 MEAS/CTN:75x42x52(cm)

材质:
 A3 钢, 西皮, 尼龙扶手
Material:
 PA nylon, plastic, A3 steel, faux leather, mesh

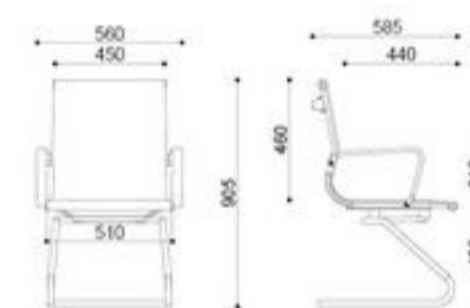

0517E-5T
 NW:12.5kgs
 GW:15kgs
 MEAS/CTN:75x42x52(cm)

材质:
 A3 钢, 台网, 尼龙扶手
Material:
 PA nylon, plastic, A3 steel, mesh

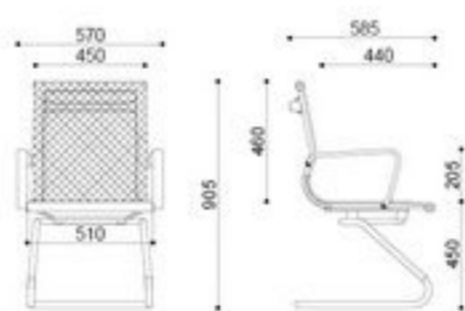

25B-1P5
 NW:16.9kgs
 GW:19.9kgs
 MEAS/CTN:82x45x52(cm)

材质:
 A3 钢, 西皮, 铝合金扶手, 铝合金脚
Material:
 Aluminum, A3 steel, faux leather, sponge, mesh

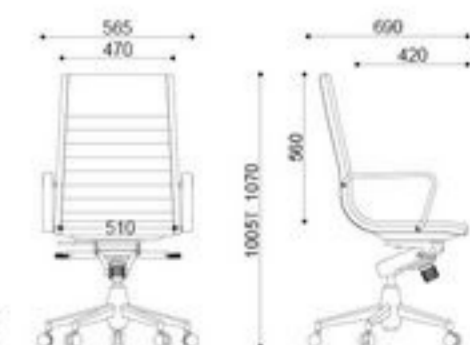



25C-1P5
 NW:16.2kgs
 GW:19.2kgs
 MEAS/CTN:78x45x52(cm)

材质:
 A3 钢, 西皮, 铝合金扶手, 铝合金脚
Material:
 Aluminum,A3 steel,faux leather,sponge,mesh

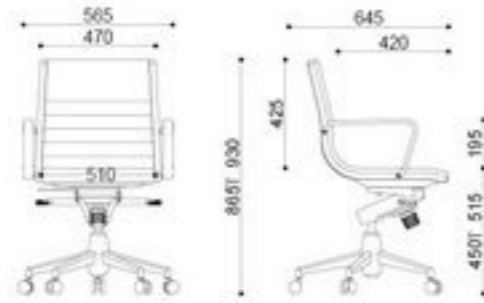

26E-5
 NW:15.5kgs
 GW:18kgs
 MEAS/CTN:65x39x52(cm)

材质:
 A3 钢, 台网, 铝合金扶手
Material:
 Aluminum,A3 steel,elastic mesh

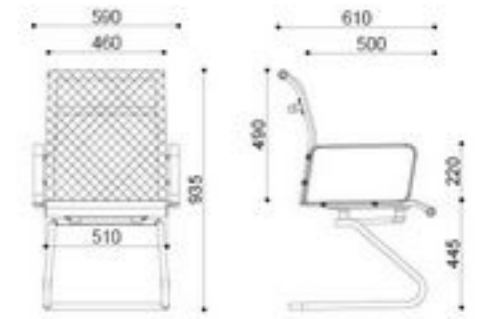

25E-5
 NW:12.5kgs
 GW:15.5kgs
 MEAS/CTN:75x42x52(cm)

材质:
 A3 钢, 西皮, 铝合金扶手
Material:
 Aluminum,A3 steel,faux leather,sponge,mesh

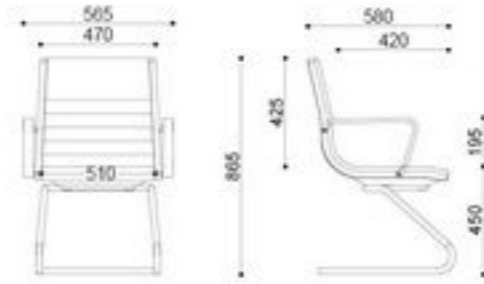

26B-1HP5
 NW:21.5kgs
 GW:24kgs
 MEAS/CTN:75x42x62(cm)

材质:
 A3 钢, 西皮, 铝合金扶手, 铝合金脚
Material:
 Aluminum,A3 steel,elastic mesh,sponge,faux leather

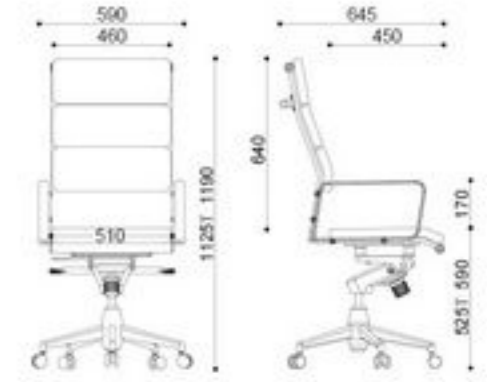

26B-1P5
 NW:20kgs
 GW:22.5kgs
 MEAS/CTN:75x42x62(cm)

材质:
 A3 钢, 台网, 铝合金扶手, 铝合金脚
Material:
 Aluminum,A3 steel,elastic mesh

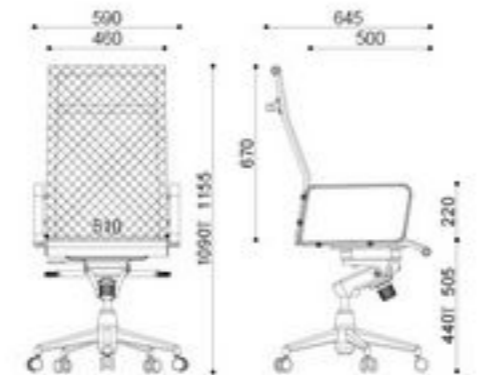

26C-1HP5
 NW:20.5kgs
 GW:23kgs
 MEAS/CTN:72x35x62(cm)

材质:
 A3 钢, 西皮, 铝合金扶手, 铝合金脚
Material:
 Aluminum,A3 steel,elastic mesh,sponge,faux leather

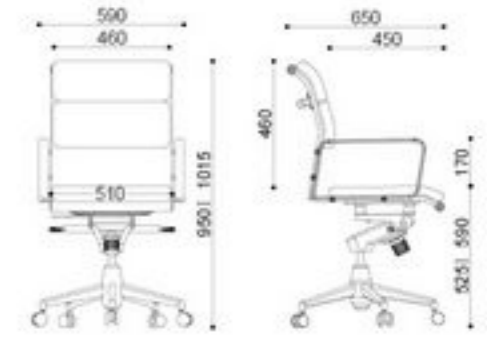

26C-1P5
 NW:19.2kgs
 GW:21.7kgs
 MEAS/CTN:72x35x62(cm)

材质:
 A3 钢, 台网, 铝合金扶手, 铝合金脚
Material:
 Aluminum,A3 steel,elastic mesh

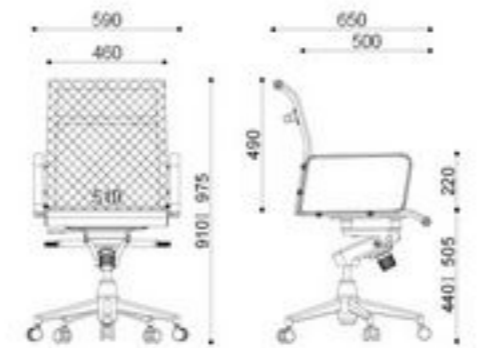

26D-1H
 NW:14.5kgs
 GW:17kgs
 MEAS/CTN:75x42x62(cm)

材质:
 A3 钢, 西皮, 铝合金扶手, 铝合金脚
Material:
 Aluminum,A3 steel,elastic mesh,sponge,faux leather

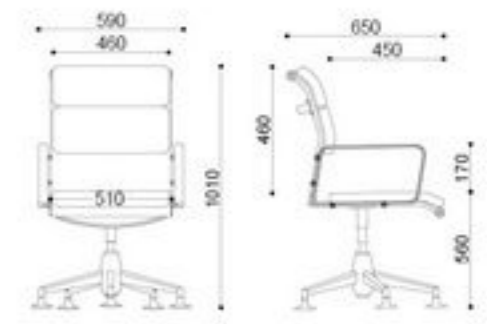

26D-1
 NW:12.9kgs
 GW:15.4kgs
 MEAS/CTN:75x35x62(cm)

材质:
 A3 钢, 台网, 铝合金扶手, 铝合金脚
Material:
 Aluminum,A3 steel,elastic mesh

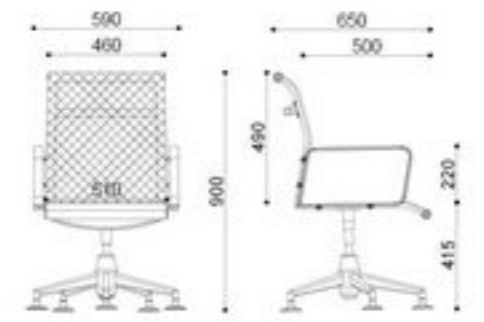

26E-5H
 NW:17.5kgs
 GW:20kgs
 MEAS/CTN:65x39x52(cm)

材质:
 A3 钢, 西皮, 铝合金扶手
Material:
 Aluminum,A3 steel,elastic mesh,sponge,faux leather

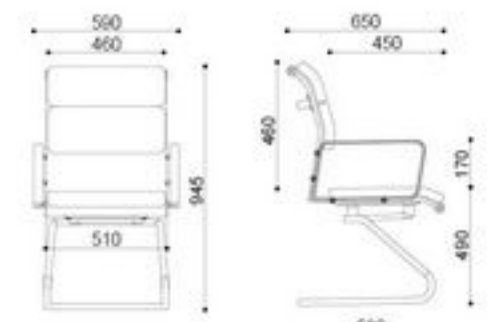



31B-1
NW:16.8kgs
GW:19.2kgs
MEAS/CTN:88x50x52(cm)

材质:
 A3 钢, 西皮, 网布, 海绵, 铝合金脚
Material:
 Aluminum,A3 steel,sponge,faux leather,mesh

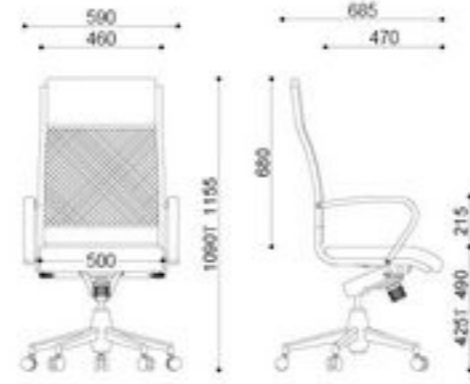

31C-1
NW:16.4kgs
GW:18.8kgs
MEAS/CTN:78x50x52(cm)

材质:
 A3 钢, 西皮, 网布, 海绵, 铝合金脚
Material:
 Aluminum,A3 steel,sponge,faux leather,mesh

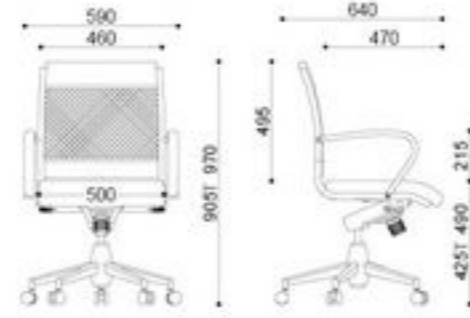

31D-1
NW:13.2kgs
GW:15.6kgs
MEAS/CTN:85x48x52(cm)

材质:
 A3 钢, 西皮, 网布, 海绵, 铝合金脚
Material:
 Aluminum,A3 steel,sponge,faux leather,mesh

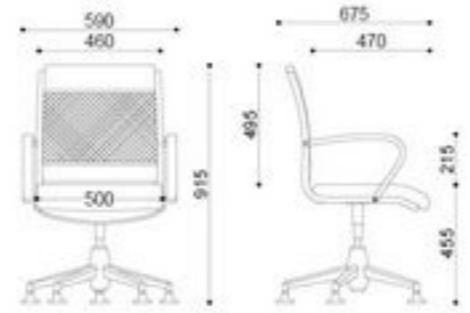

31E-5
NW:12.6kgs
GW:15kgs
MEAS/CTN:80x45x52(cm)

材质:
 A3 钢, 西皮, 网布, 海绵
Material:
 Aluminum,A3 steel,sponge,faux leather,mesh

